

WINGBURG

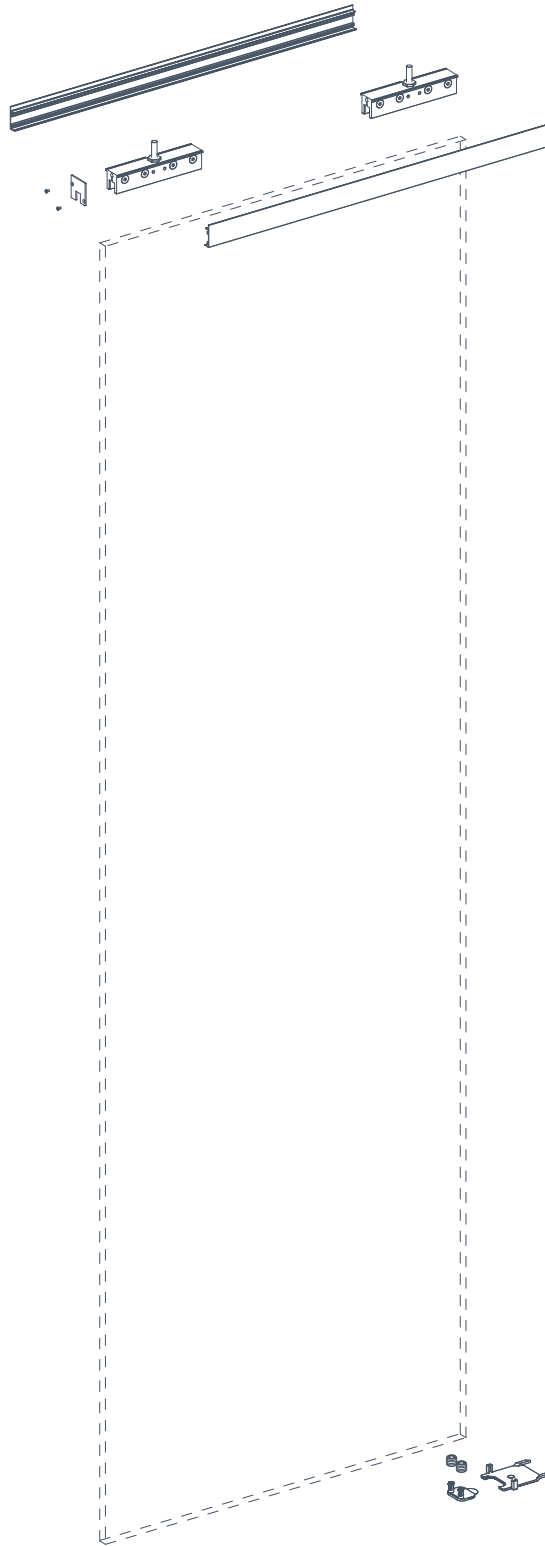

Montageanleitung

Basis ESG-Klemmbeschlagset

BELPORT **GLAS**

Sicherheitshinweise	3
Benötigtes Werkzeug	3
Lieferumfang	4
Montage	6 - 13



Sicherheitshinweise

Vor der Montage, lesen Sie bitte die Montageanleitung sorgfältig. Bei Verständnisschwierigkeiten wenden Sie sich an den Kundendienst oder Ihren Lieferanten. Um das erworbene Produkt fachgerecht montieren zu können, verwenden Sie bitte die auf der folgenden Seite angegebenen Werkzeuge. Da einige Bleche scharfe Kanten aufweisen können, schützen Sie unbedingt ihre Hände vor Schnittverletzungen und Arbeitsflächen vor Kratzern. Achten Sie während der Montage stets auf eine ergonomische Arbeitsweise und montieren sie nur alleine, wenn Sie eine Gefährdung Ihrer Gesundheit oder anderer Personen ausschließen können. Alle Bauteile wurden vor dem Ausliefern durch „Wingburg“ auf Unversehrtheit überprüft. Für Schäden die auf eine unsachgemäße Montage oder den Transport zurückzuführen sind, übernimmt „Wingburg“ keine Haftung.

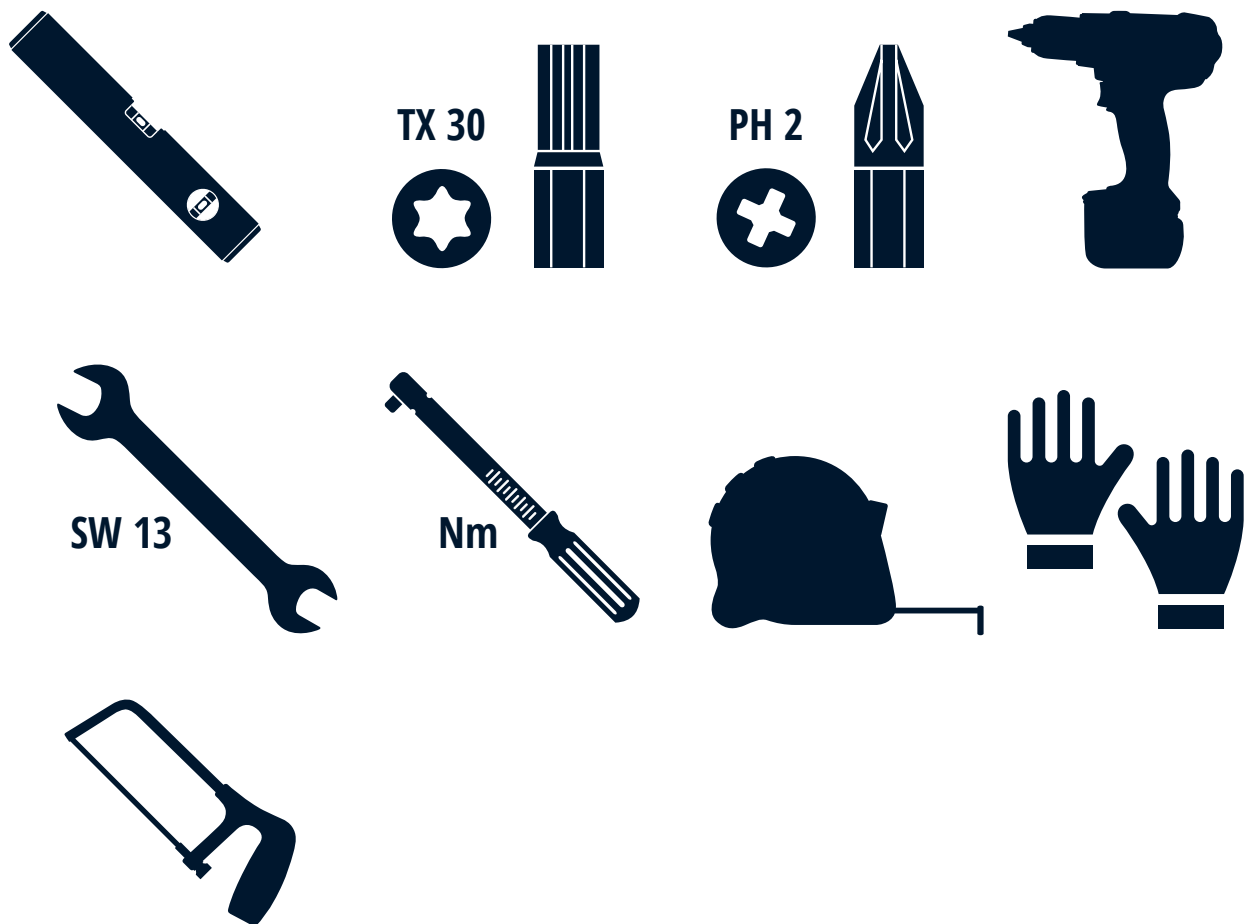
Benötigtes Werkzeug

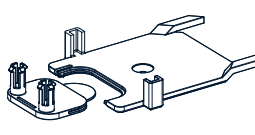

Bauteile

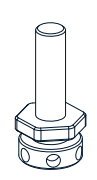
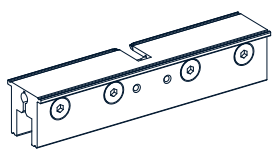
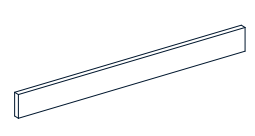
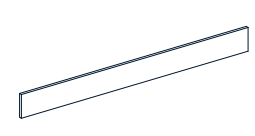
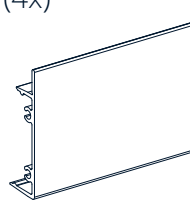
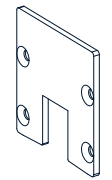
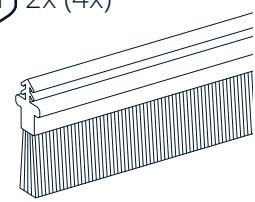
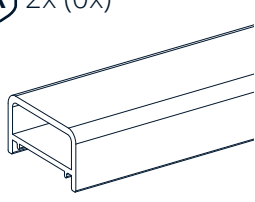
<p>a 1x (2x)</p>  <p>8 mm Bodenführung</p>	<p>b 1x (2x)</p>  <p>8 mm 10 mm</p> <p>10 mm Bodenführung</p>	<p>c 2x (4x)</p>  <p>Höhenverstellungsschraube</p>	<p>d 2x (4x)</p>  <p>Glasklemmbacke</p>
<p>e 4x (8x)</p>  <p>8 mm Klemmgummi</p>	<p>f 4x (8x)</p>  <p>10 mm Klemmgummi</p>	<p>g 2x (4x)</p>  <p>Klemmbackenblende</p>	<p>h 1x (2x)</p>  <p>Endkappe</p>
<p>i 2x (4x)</p>  <p>Bürstendichtung</p>	<p>k 2x (0x)*</p>  <p>Einlaufprofilblende</p>		

* Die Einlaufprofilblenden sind bereits vormontiert wenn Beschlag und Einlaufelement zusammen bestellt werden.

Normteile

<p>t 4x (8x)</p>  <p>3 x 10</p>

-x = einflügelig, (-x) = zweiflügelig

Alle Bauteile im Überblick

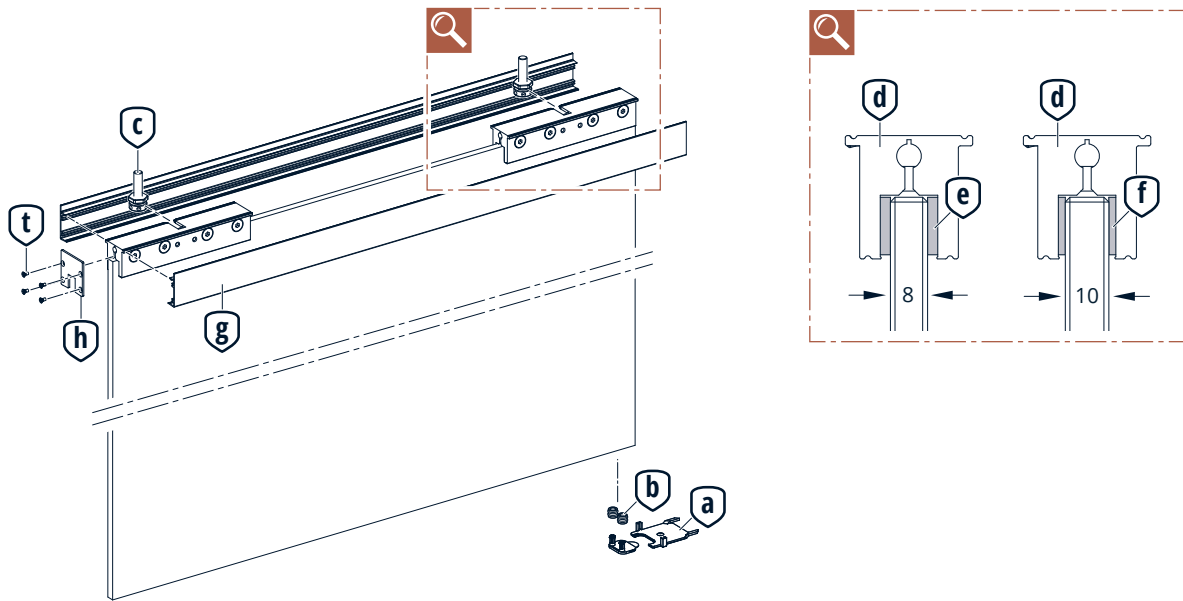

MONTAGE | BELPORT GLAS

1.

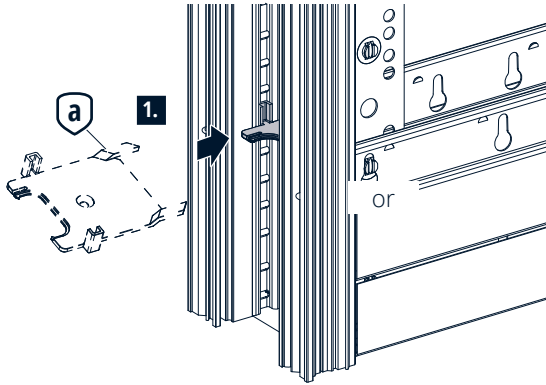

i Wenn **keine** Fußbodenheizung verbaut wurde, darf die Bodenführung gegebenenfalls auch verschraubt werden.

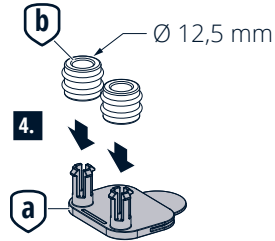
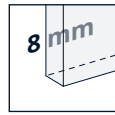
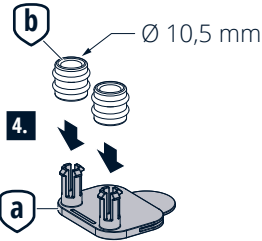
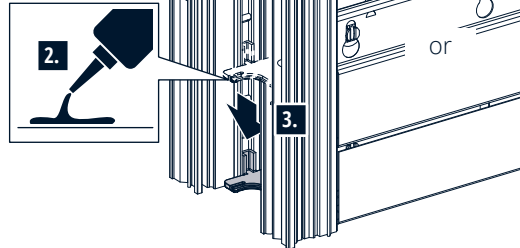

i Die Bodenführung kann auch erst nach dem Einhängen des Türblatts eingeklipst werden.

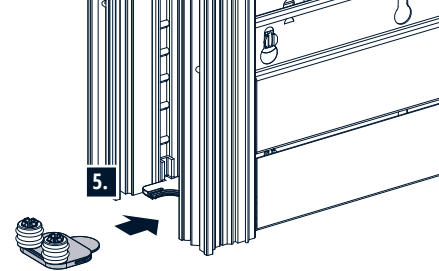

2.

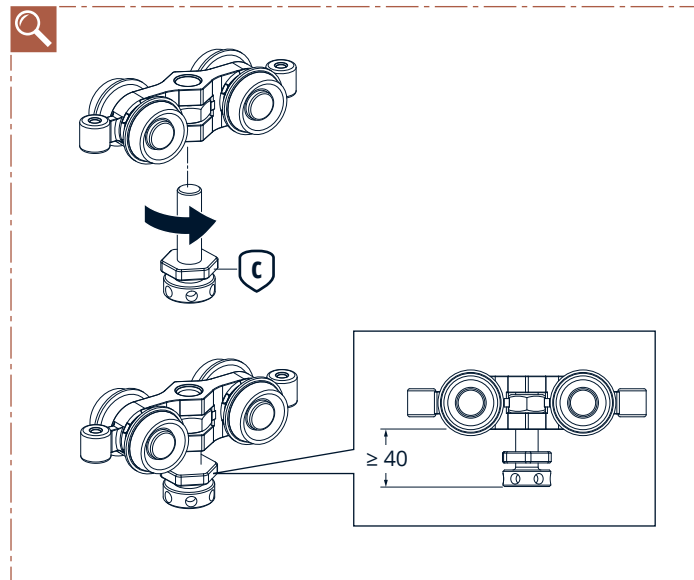
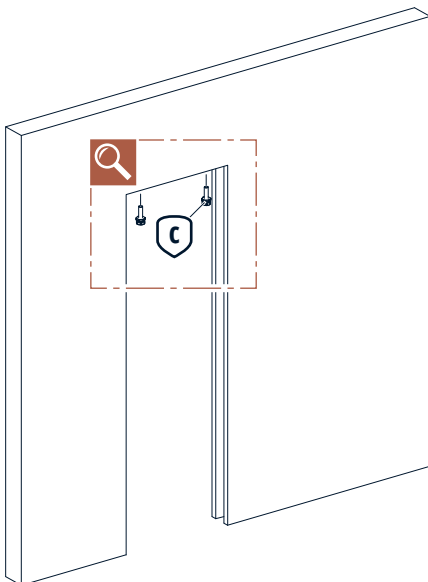

3.

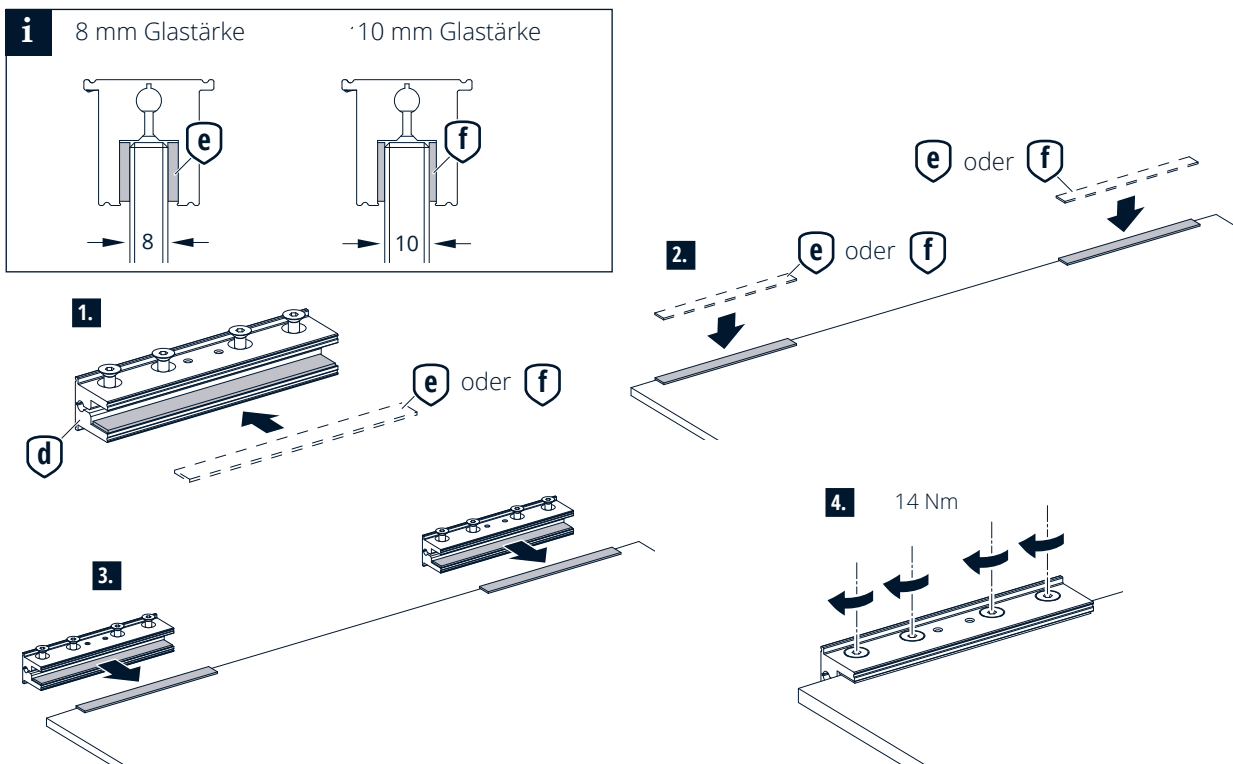
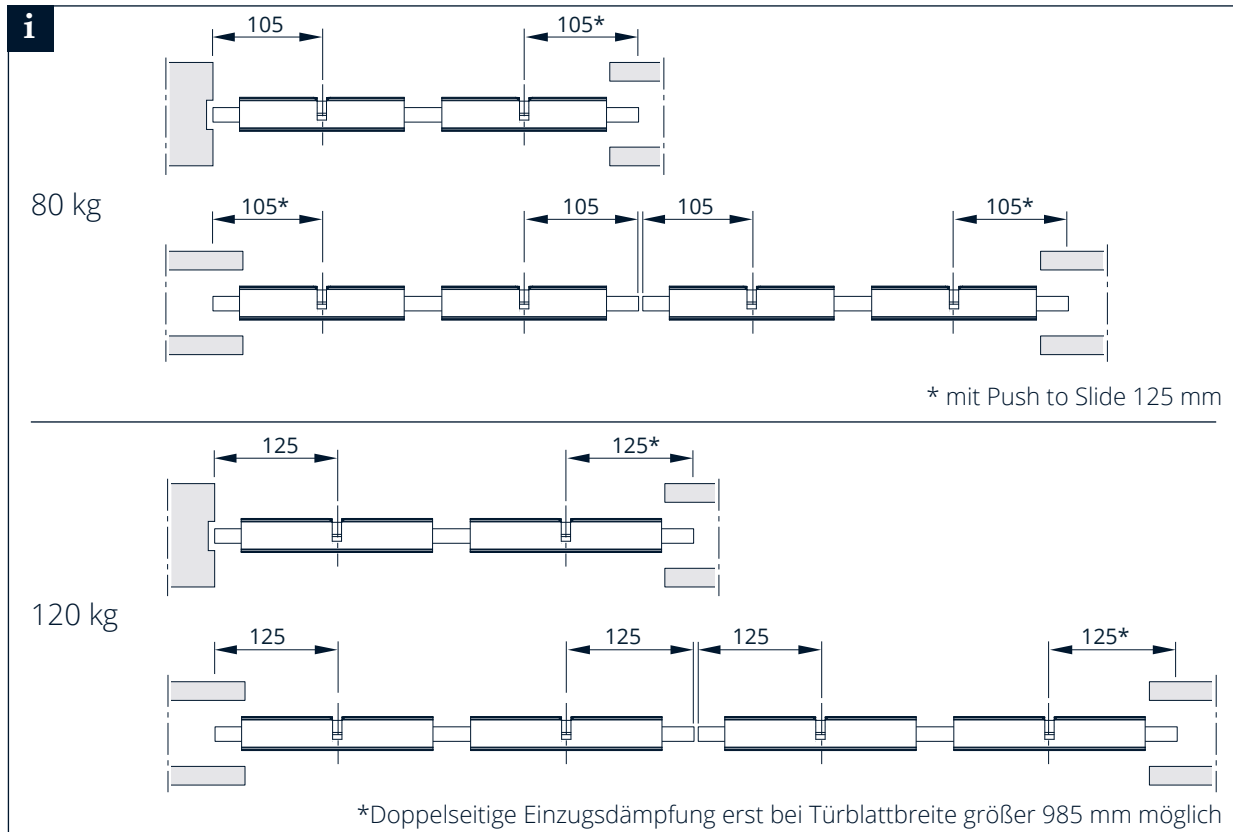

4.

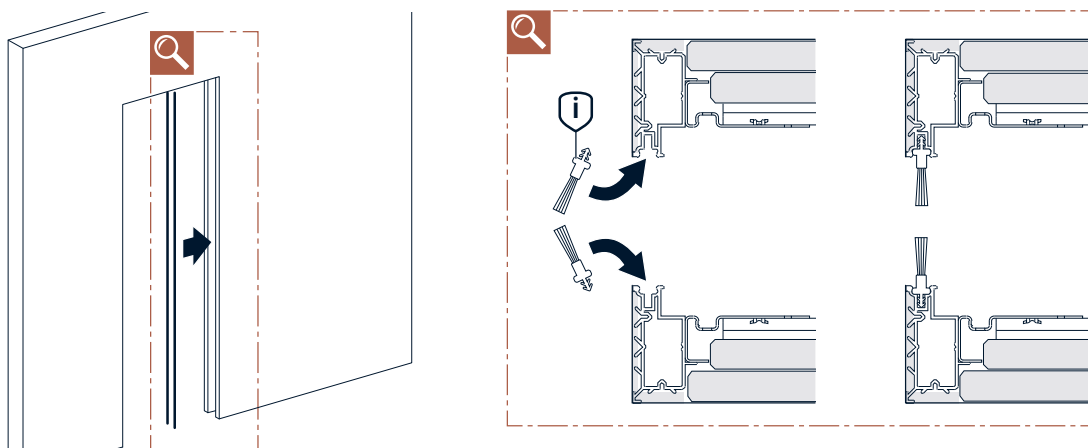

5.

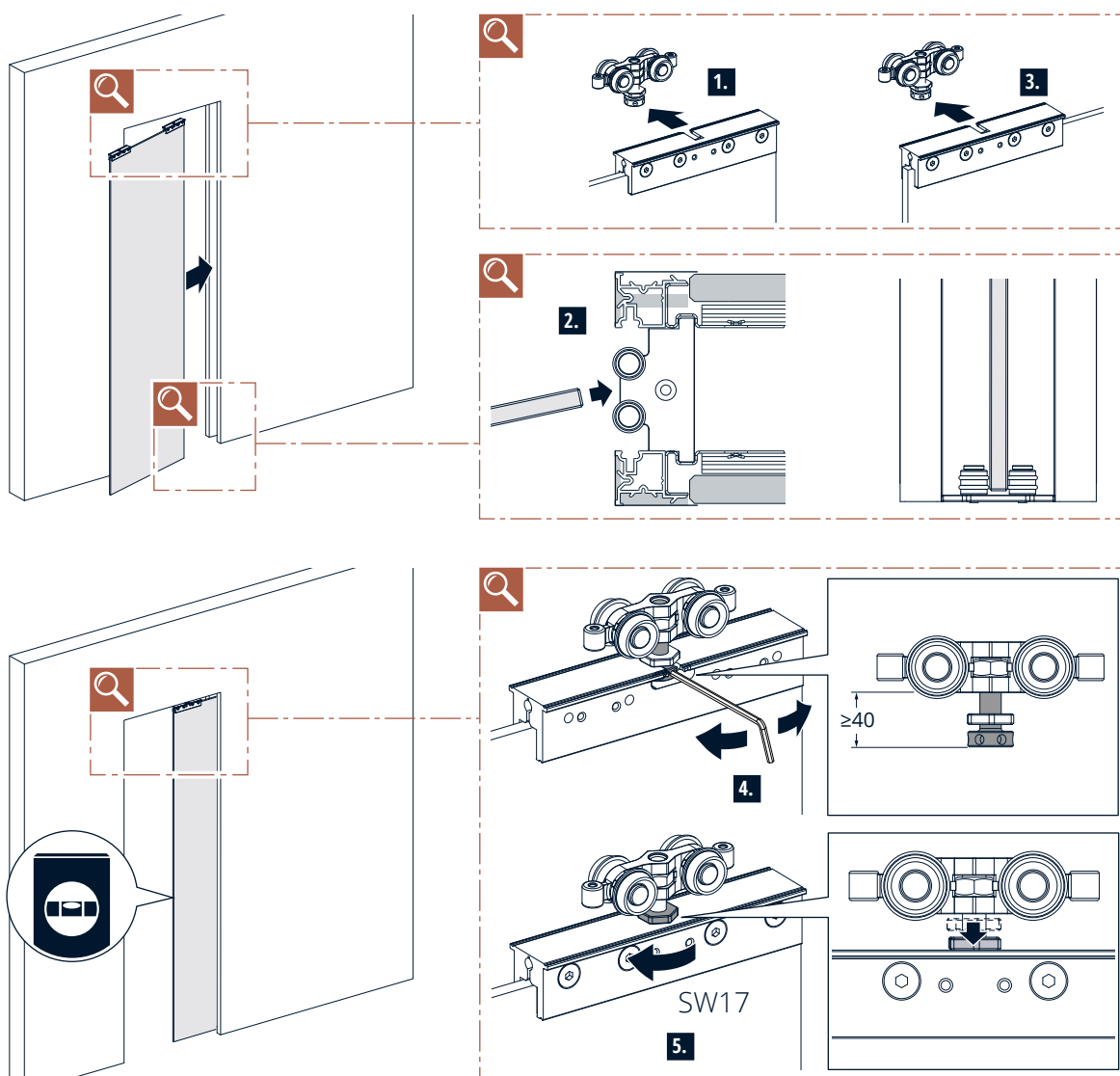

6.

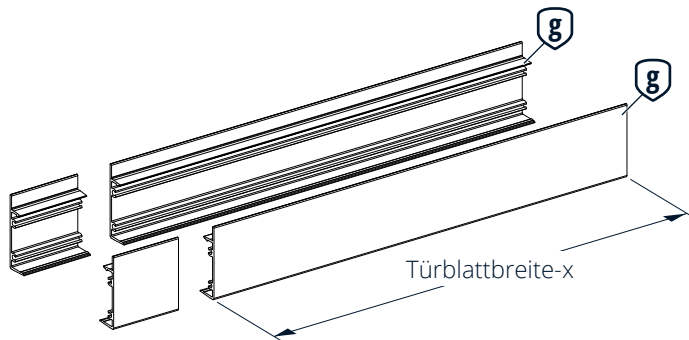
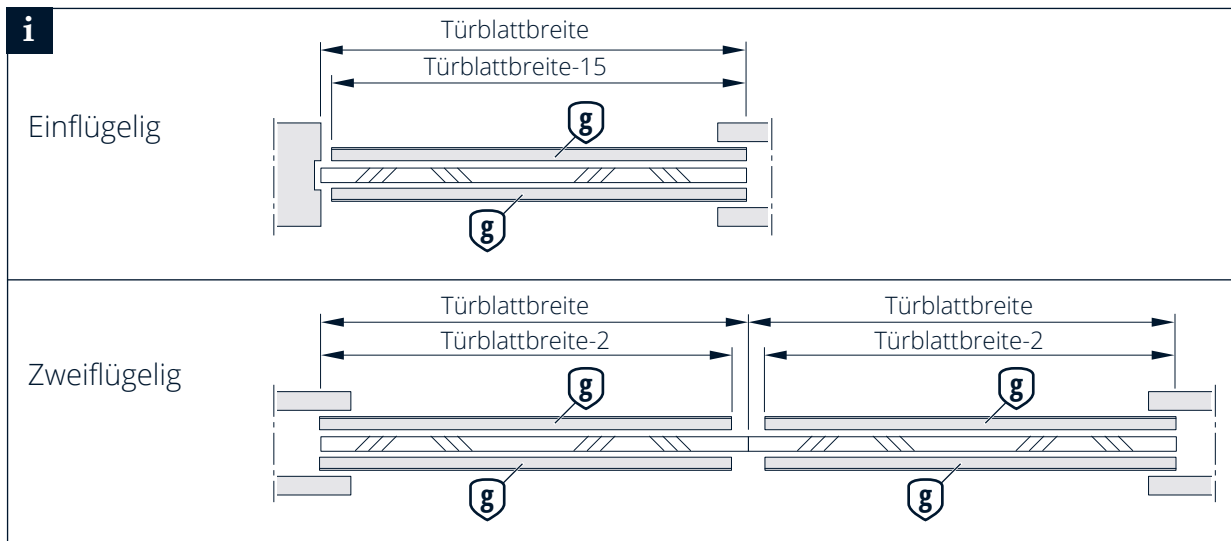

	X
Single-leaf	15 mm
Double-leaf	2 mm

7.

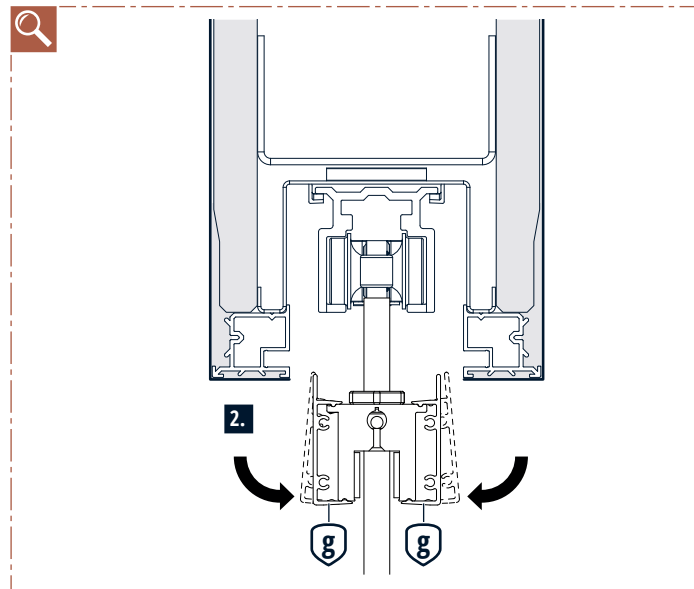
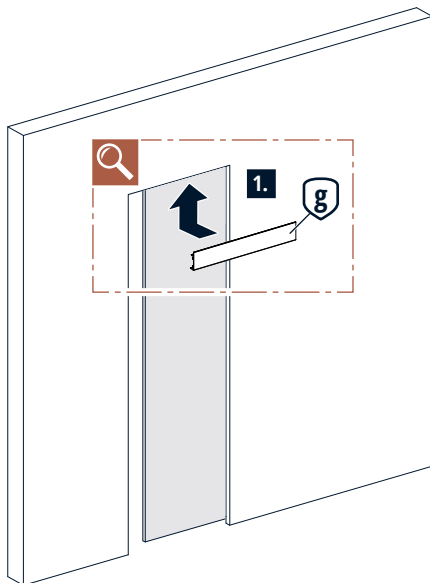
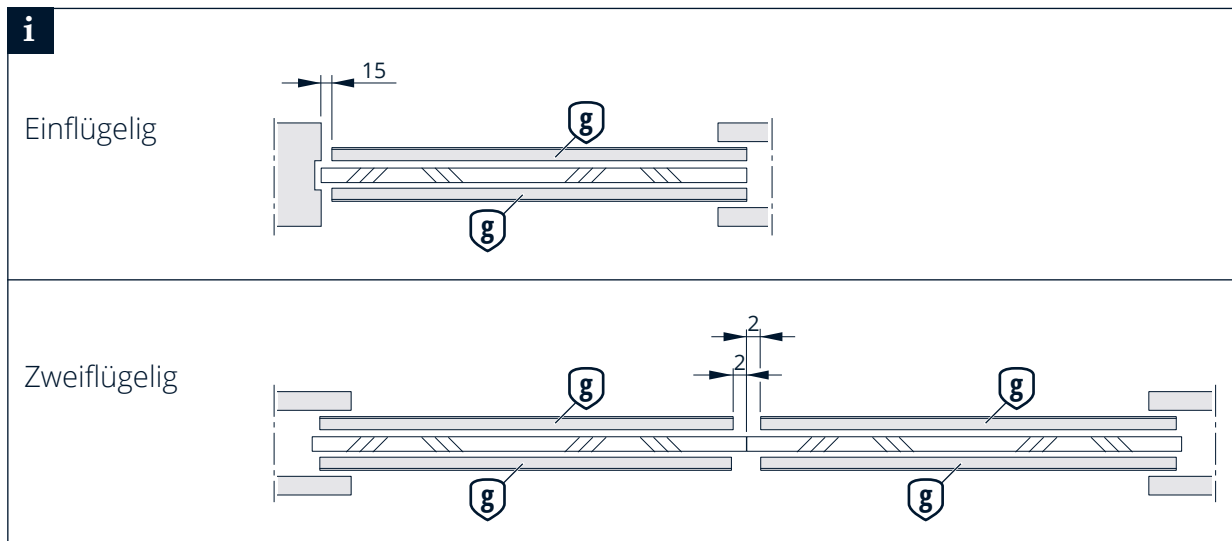

8.

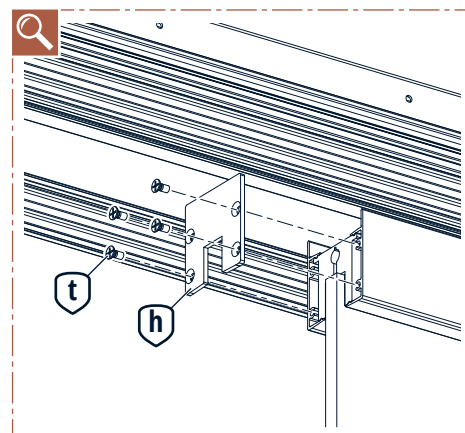
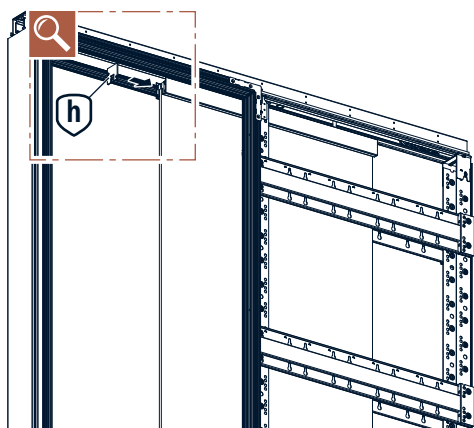

9.

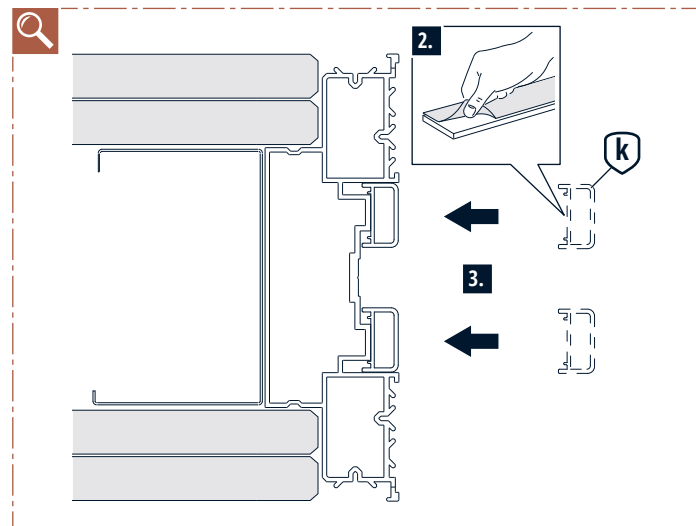
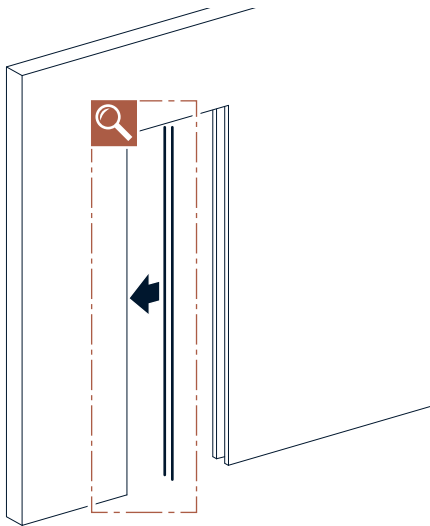
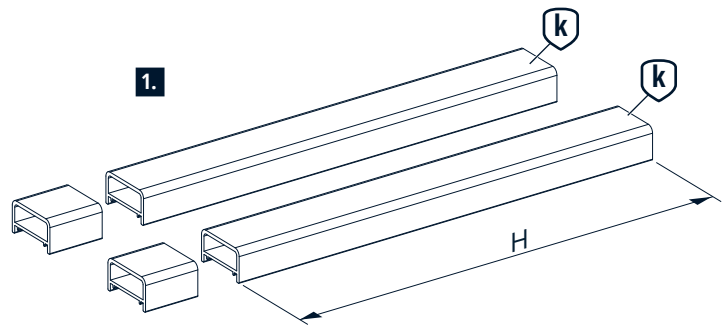
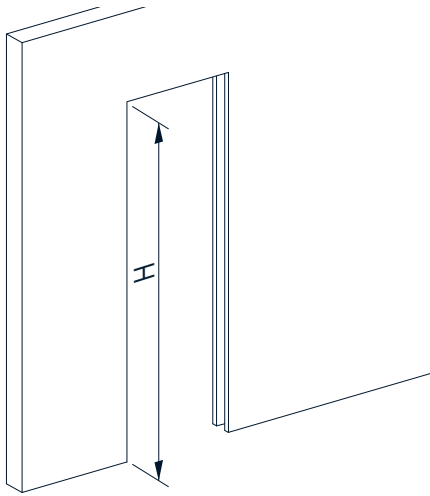

10.

Horizontalschnitt

Vertikalschnitt

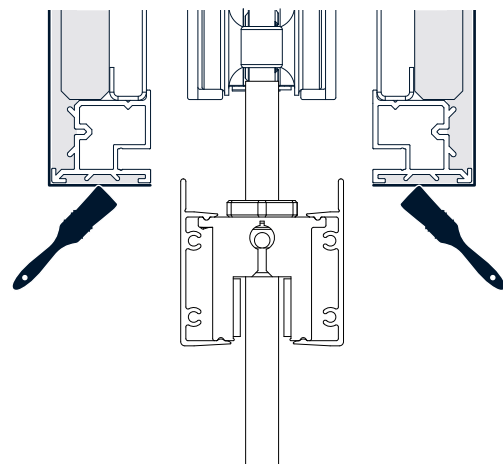
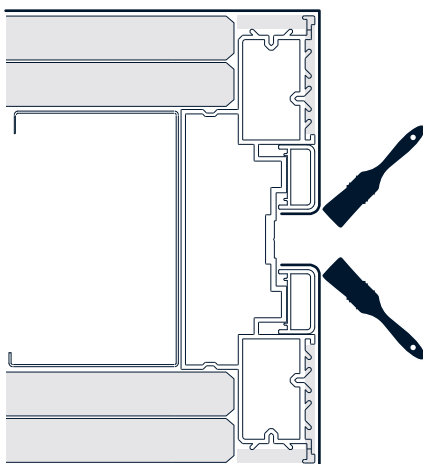

11.

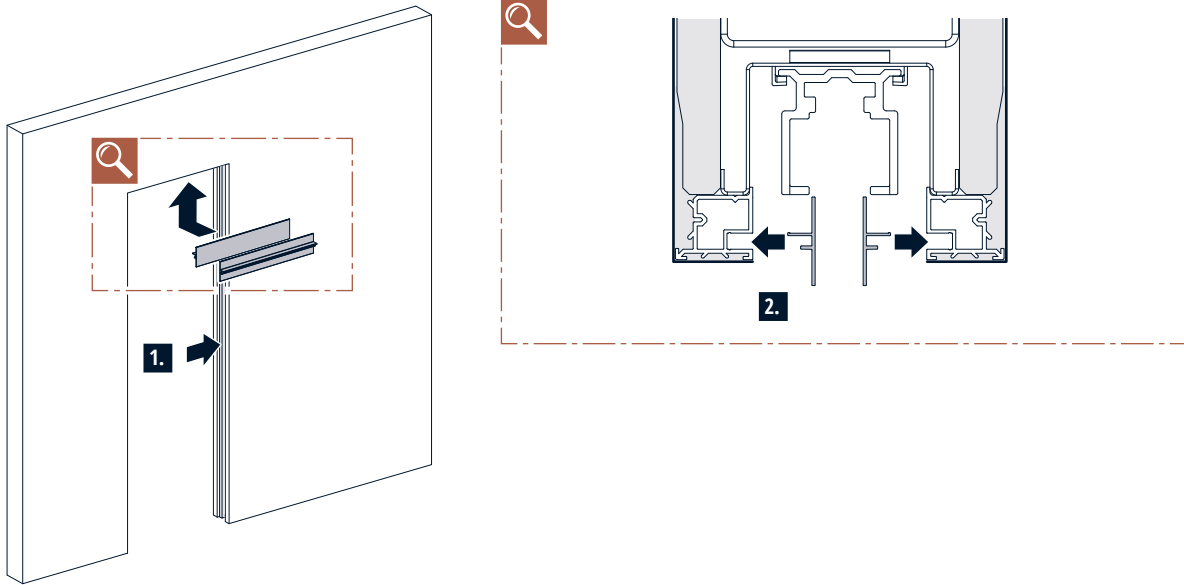

12.

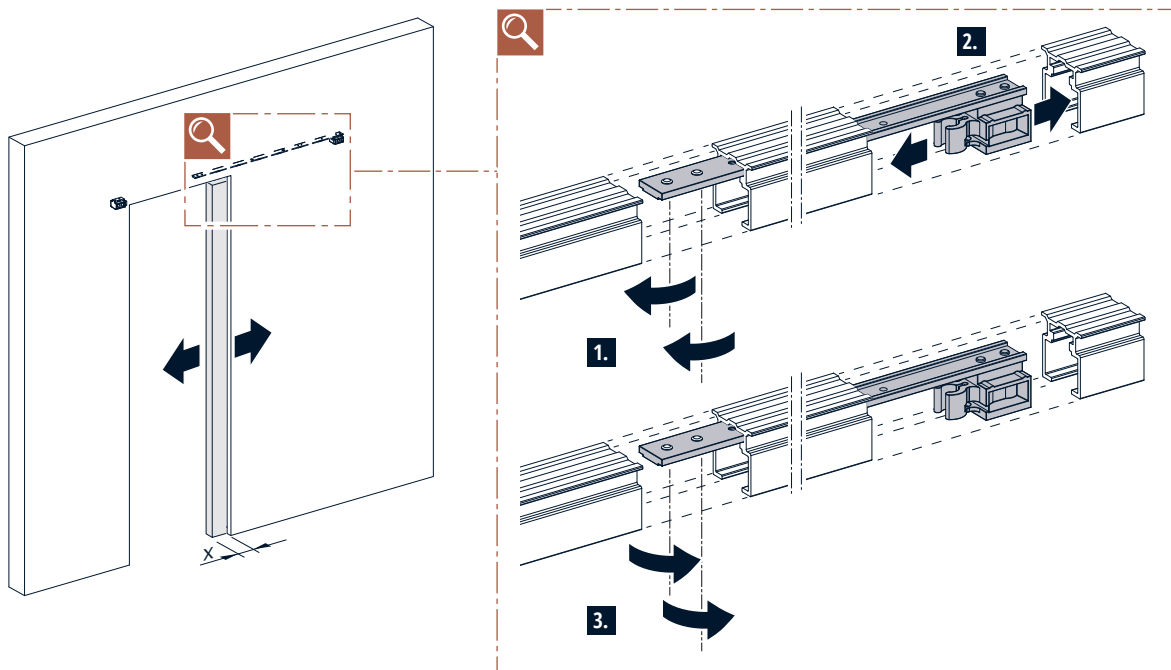



WINGBURG

 **+49.5257.94792-0**
 **info@wingburg.de**
 **www.wingburg.de**