

WINGBURG®

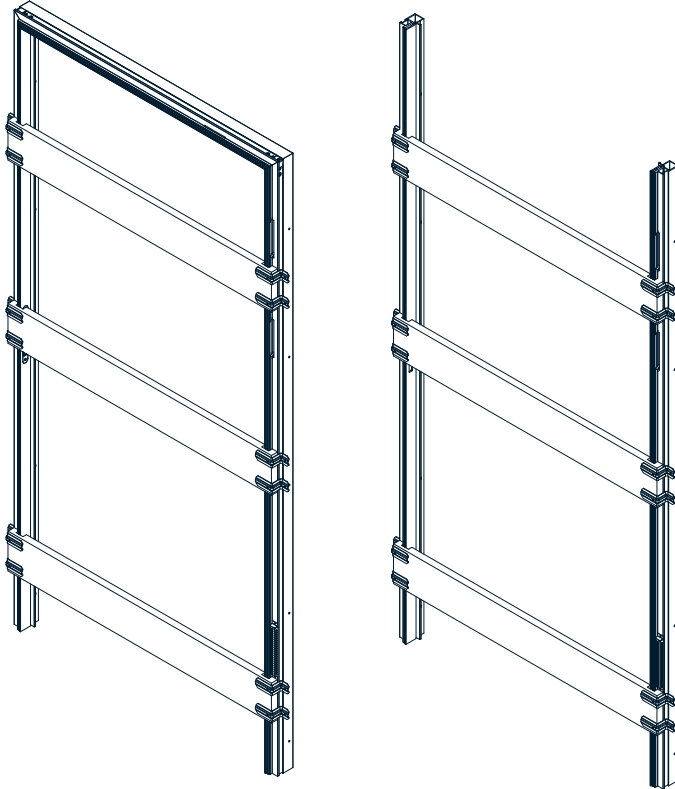
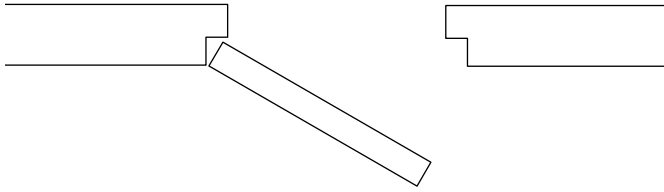

Montageanleitung

Einbauelemente für Drehtüren zum Ziehen

KONTURA **K1TZ**

Seitenverzeichnis

Sicherheitshinweise	3
Benötigtes Werkzeug	3



K1TZ-S*

Lieferumfang	4 - 5
Montage	6-13



K1TZ-G**

Lieferumfang	14-15
Montage	16-22

Verarbeitungshinweise	23
-----------------------	----

* mit Türsturz; ** geschosshoch

Sicherheitshinweise





Vor der Montage, lesen Sie bitte die Montageanleitung sorgfältig. Bei Verständnisschwierigkeiten wenden Sie sich an den Kundendienst oder Ihren Lieferanten. Um das erworbene Produkt fachgerecht montieren zu können, verwenden Sie bitte die auf der folgenden Seite angegebenen Werkzeuge. Da einige Bleche scharfe Kanten aufweisen können, schützen Sie auch unbedingt ihre Hände und Arbeitsflächen vor Schnittverletzungen. Achten Sie während der Montage stets auf eine ergonomische Arbeitsweise und montieren sie nur alleine, wenn Sie eine Gefährdung Ihrer Gesundheit oder anderer Personen ausschließen können. Alle Bauteile wurden vor dem Ausliefern durch „Wingburg“ auf Unversehrtheit überprüft. Für Schäden die auf eine unsachgemäße Montage oder den Transport zurückzuführen sind, übernimmt „Wingburg“ keine Haftung.

Benötigtes Werkzeug



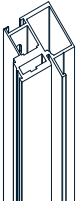

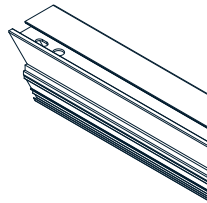
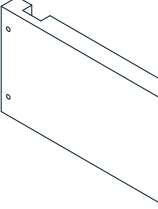
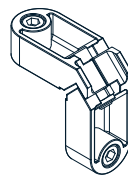
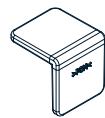
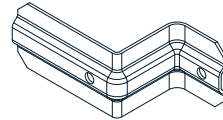
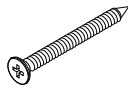
Bauteile

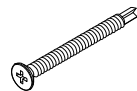
<p>a 1x</p>  <p>Zargenprofil links</p>	<p>b 1x</p>  <p>Zargenprofil rechts</p>	<p>c 1x</p>  <p>Zargenquerstück</p>	<p>d 2x*</p>  <p>OSB-Distanzbrett</p>
<p>e 2x</p>  <p>Eckverbinder</p>	<p>f 2x</p>  <p>Winkel</p>	<p>g 8x*</p>  <p>Anschlagwinkel</p>	<p>h 8x*</p>  <p>Blechschrabe 4,8 x 50</p>
<p>i 1x</p>  <p>Gummidichtung</p>	<p>j 12x</p>  <p>Bohrkopfschraube</p>		

*Die Anzahl wird auf die jeweilige Einbauhöhe des Sets abgestimmt und kann unterschiedlich ausfallen.



Alle Bauteile im Überblick

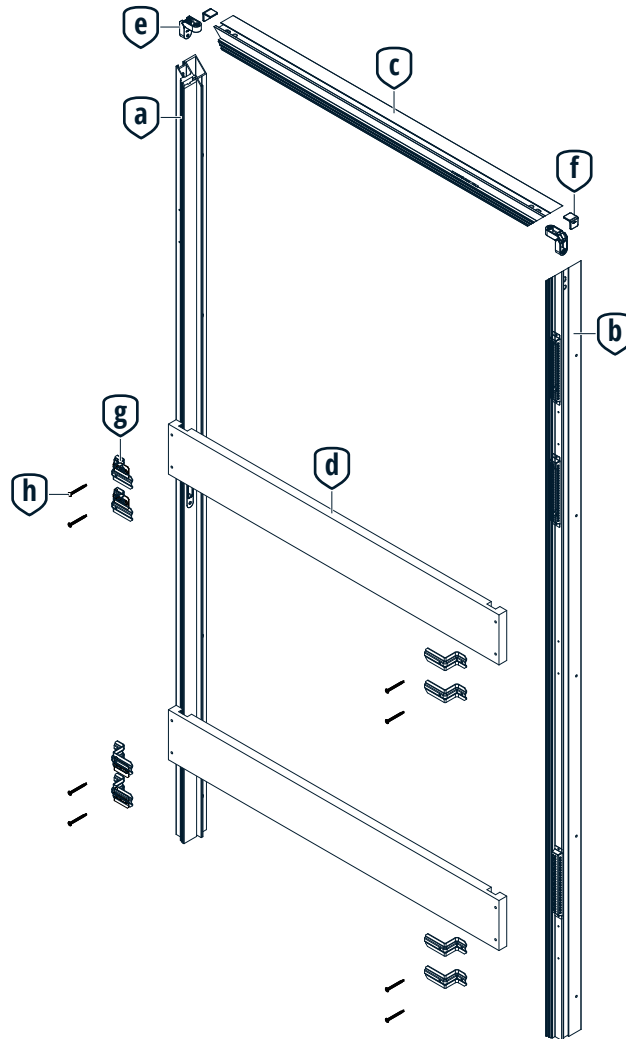



1.

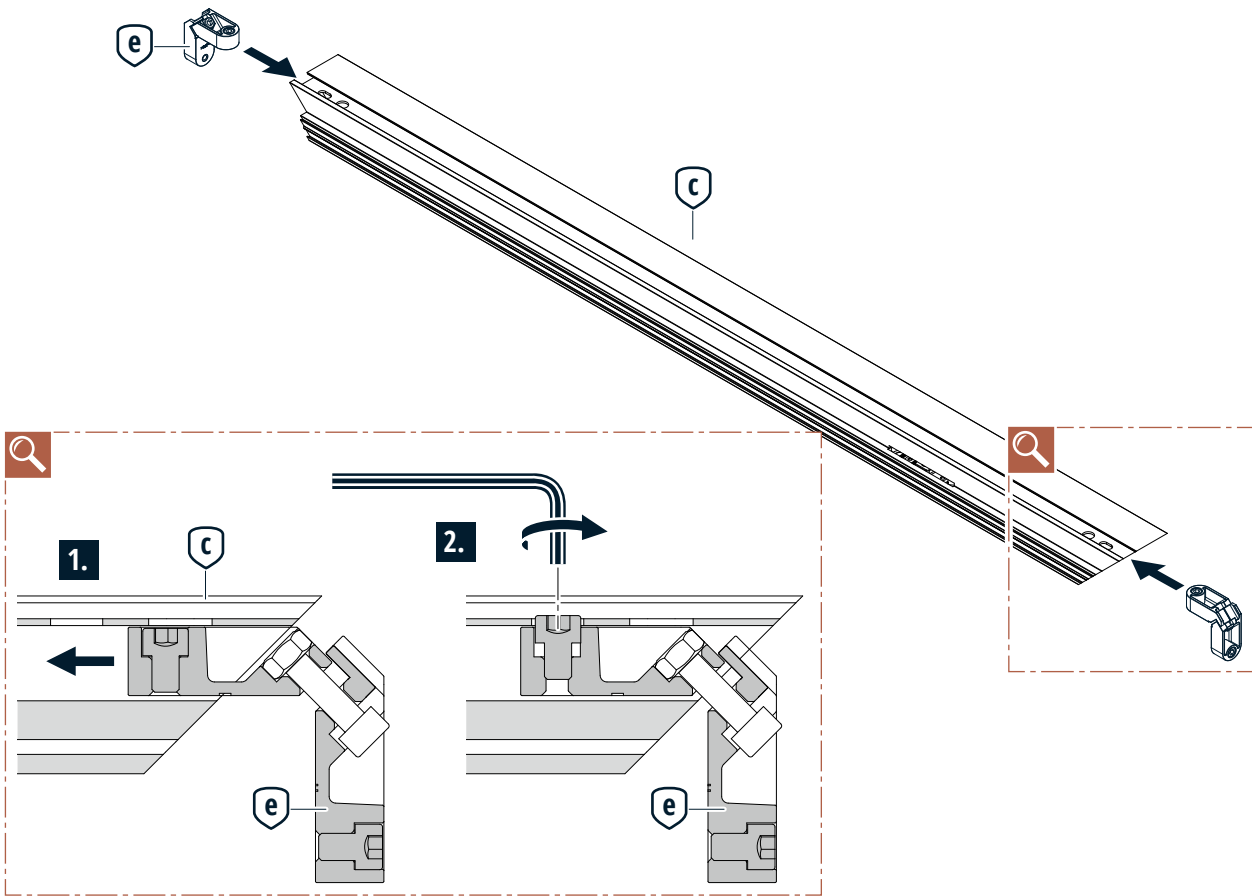

2.

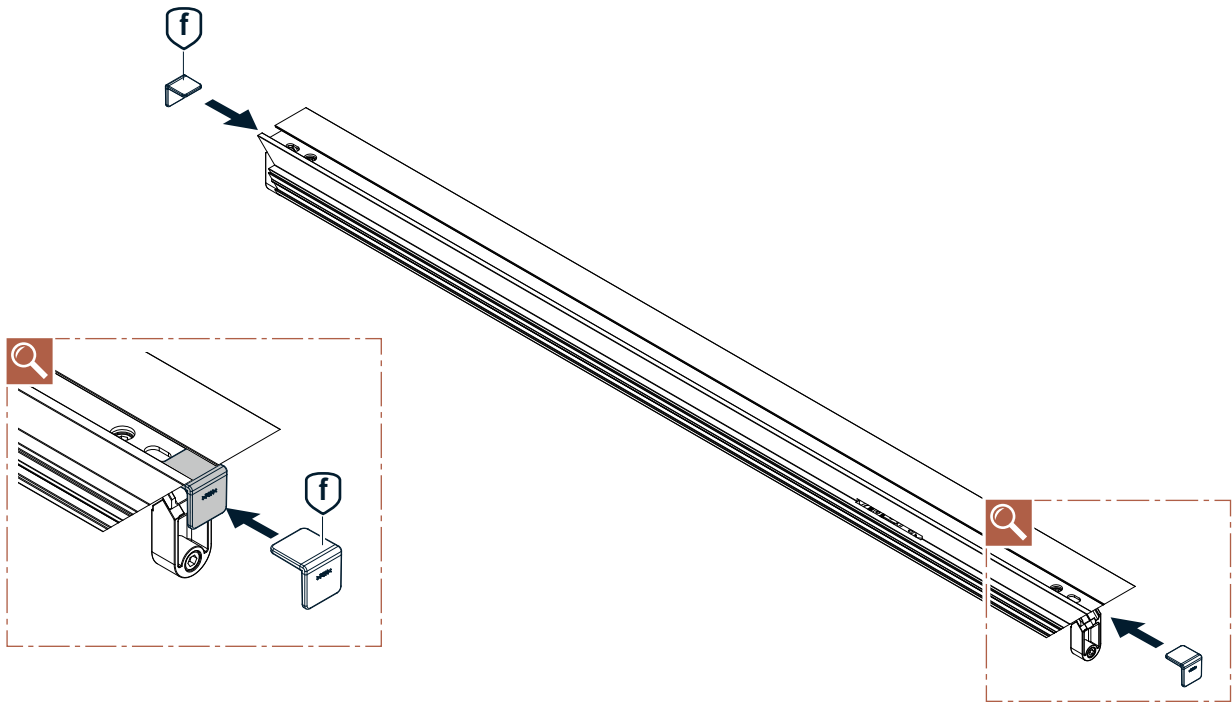



3.

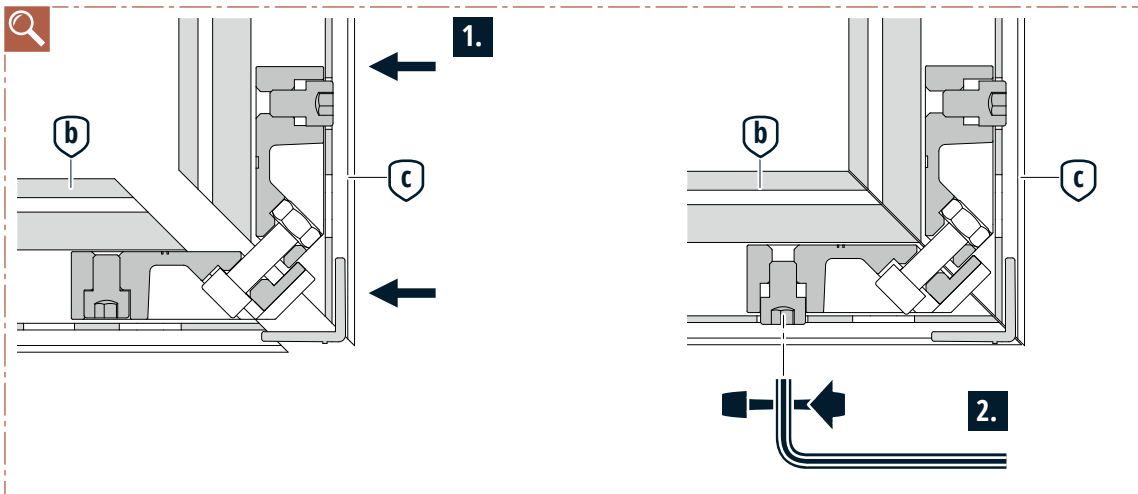
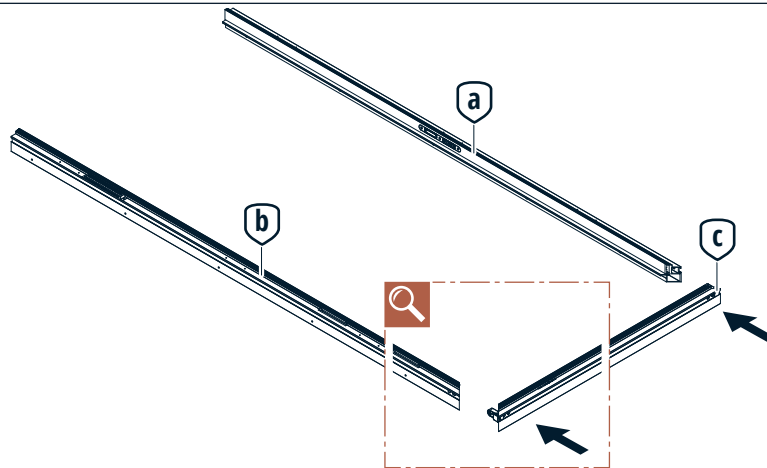

4.

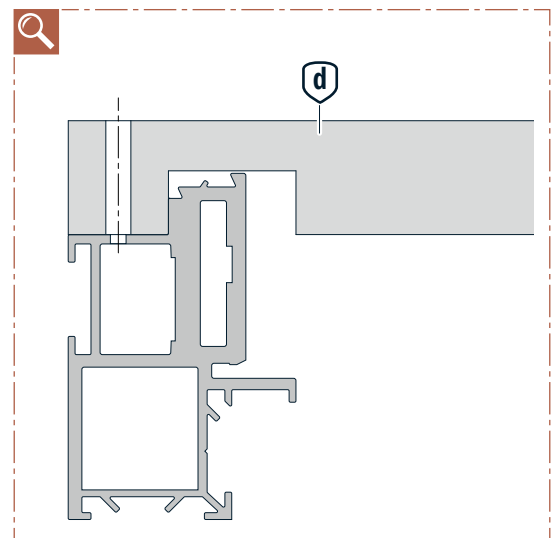
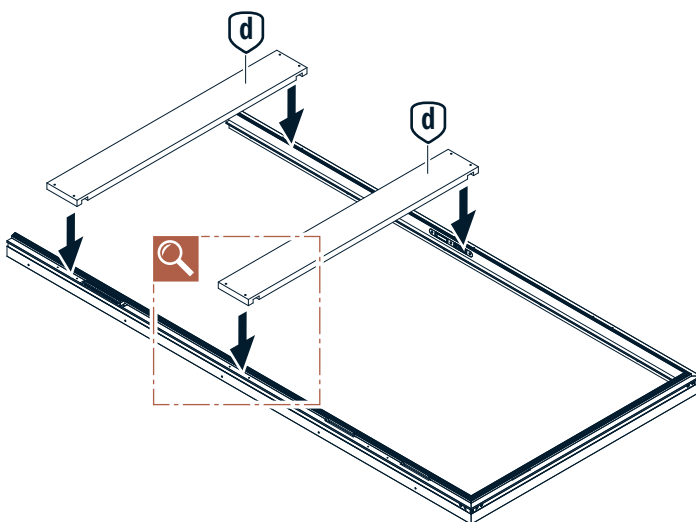



5.

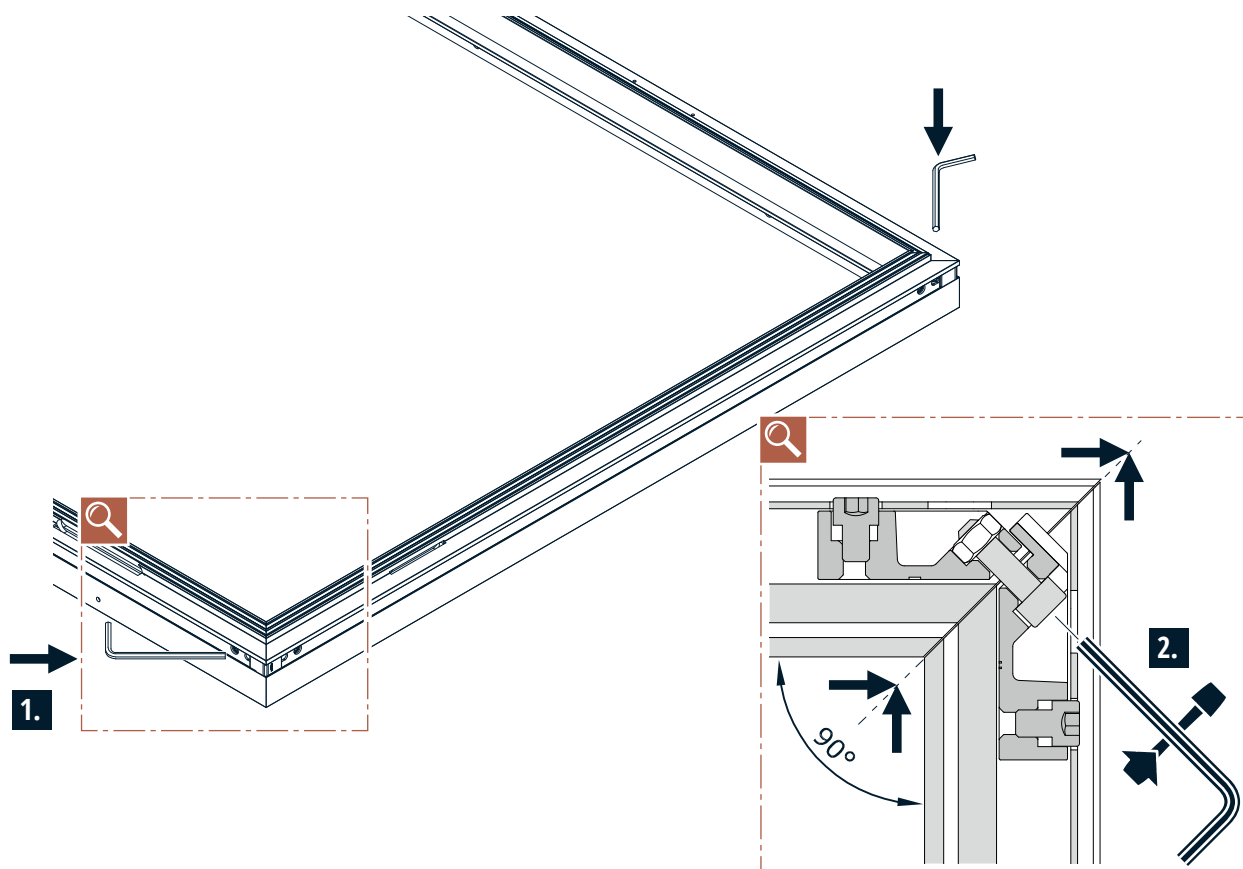

6.

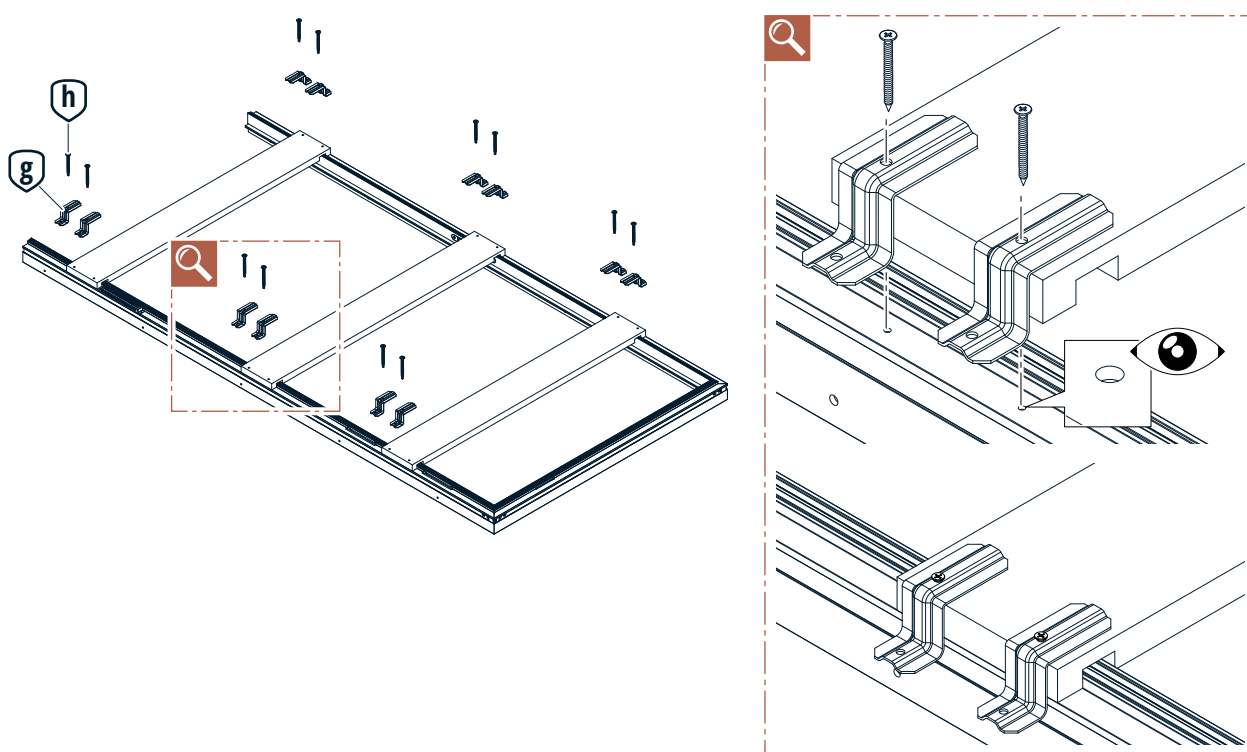



7.

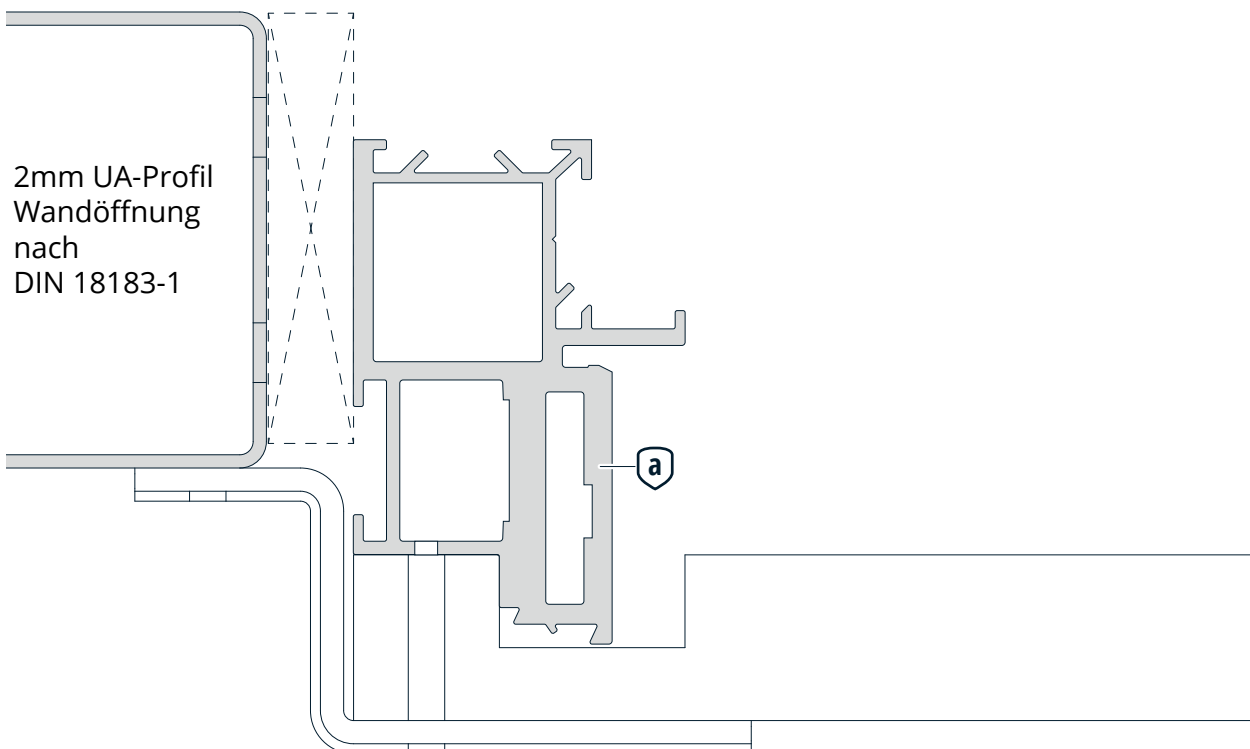
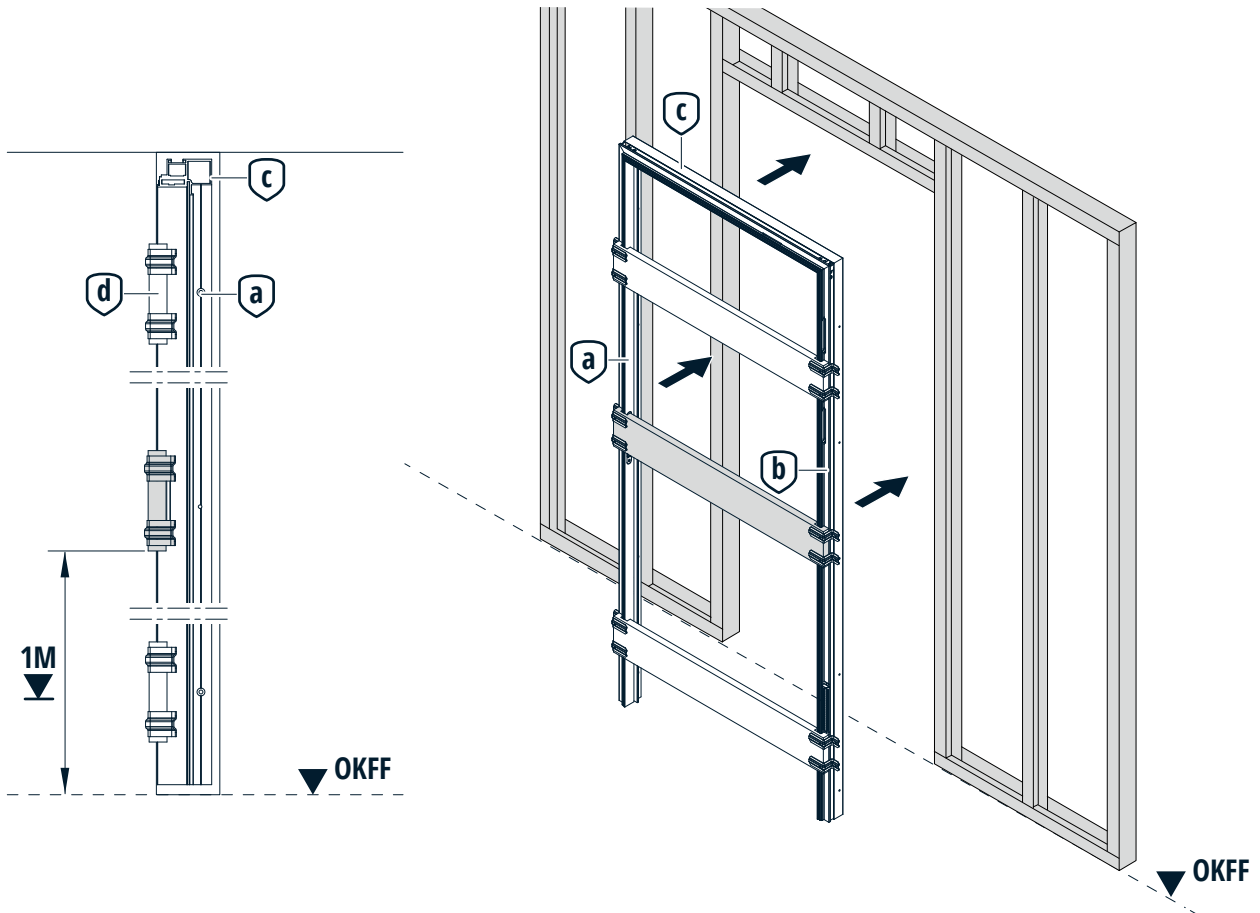



8.

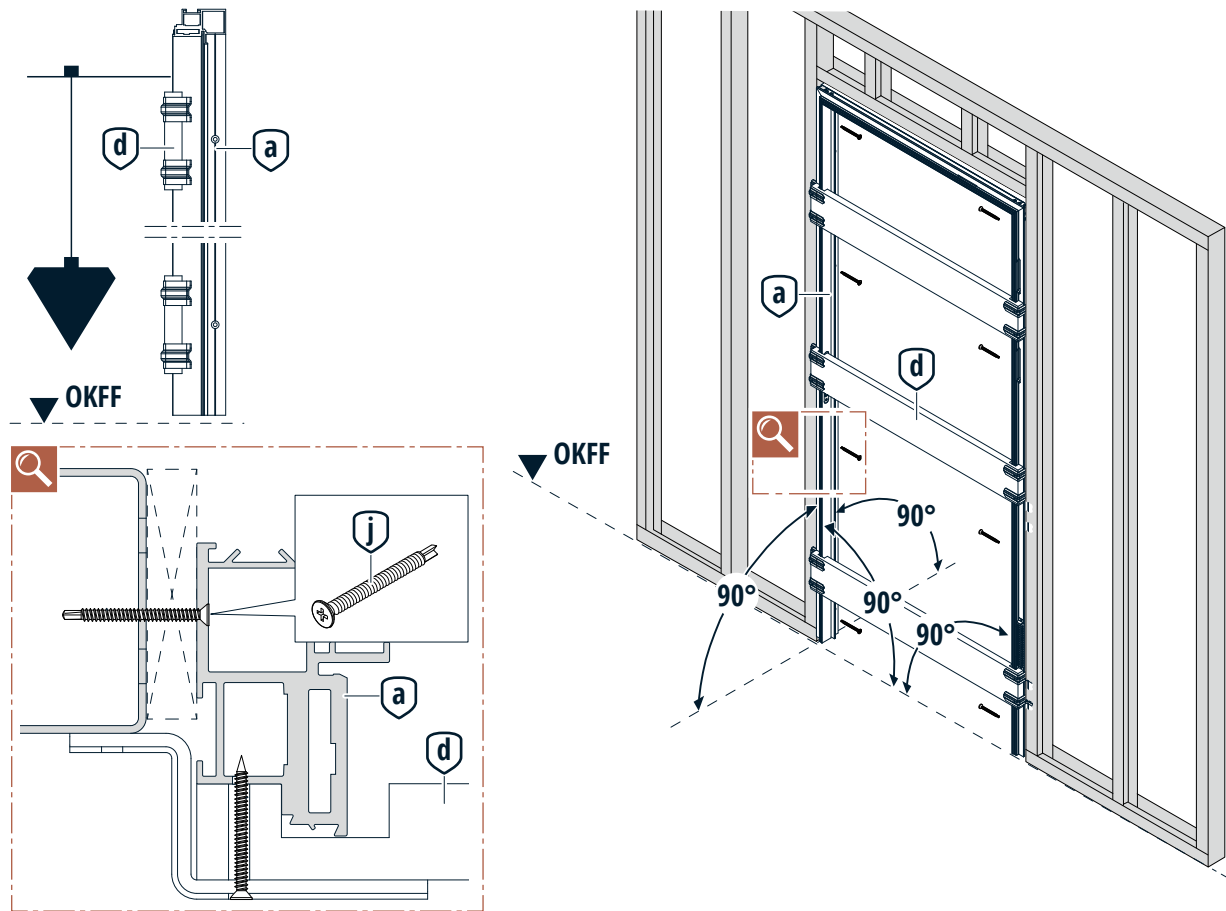

9.

HINWEIS:
Erst nach kompletter Verankerung
entfernen!

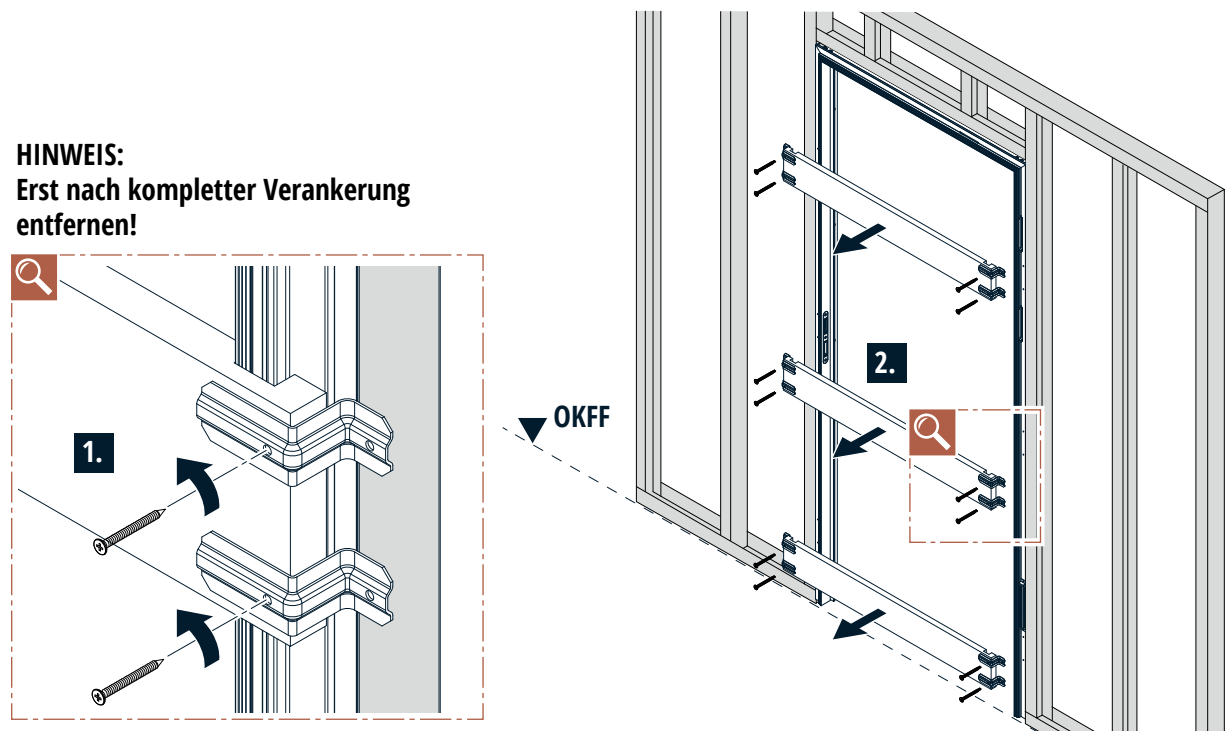



10.

HINWEIS:
Verarbeitungsrichtlinien für die Plattenstöße im Türbereich prüfen!

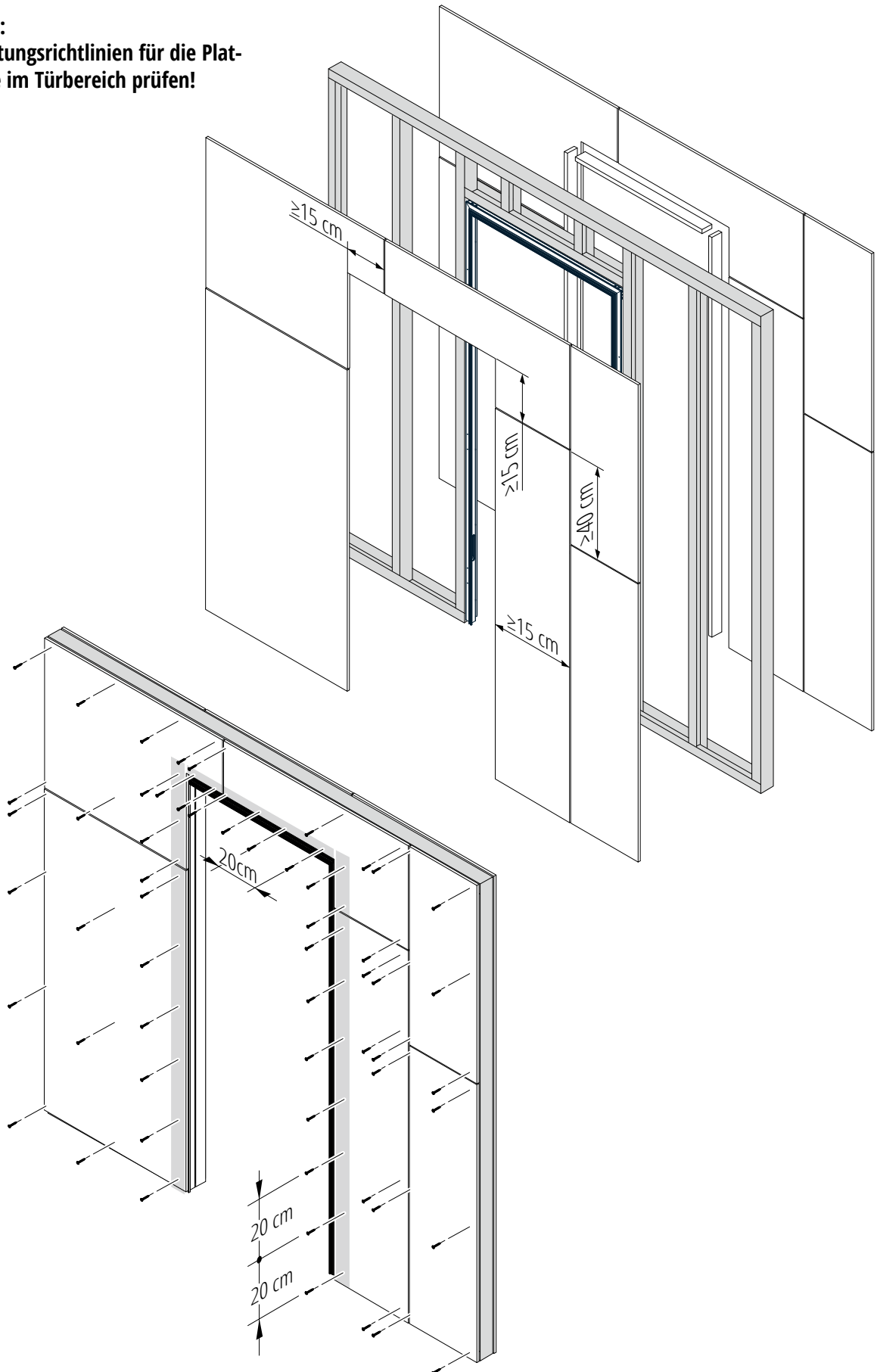



11.

A

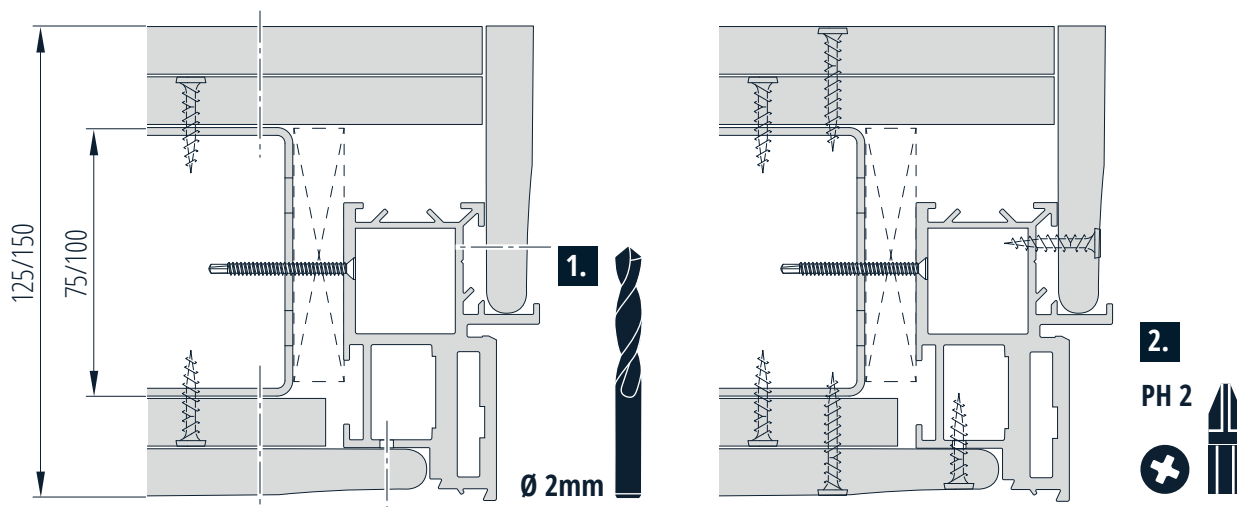

B

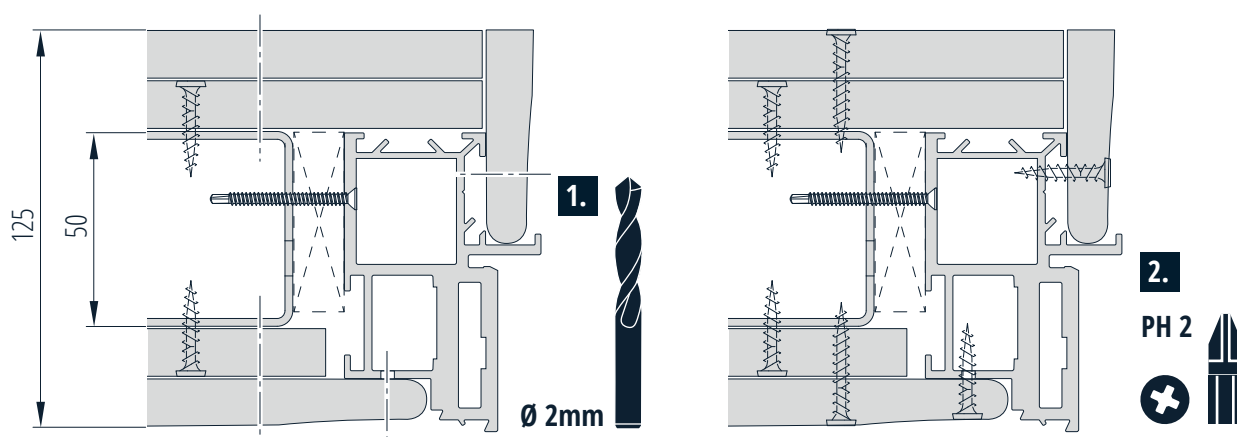



12.

HINWEIS:

Die Verwendung von kunststoffvergüteter Spachtelmasse mit Glasfaser- Fugendeckstreifen wird empfohlen.

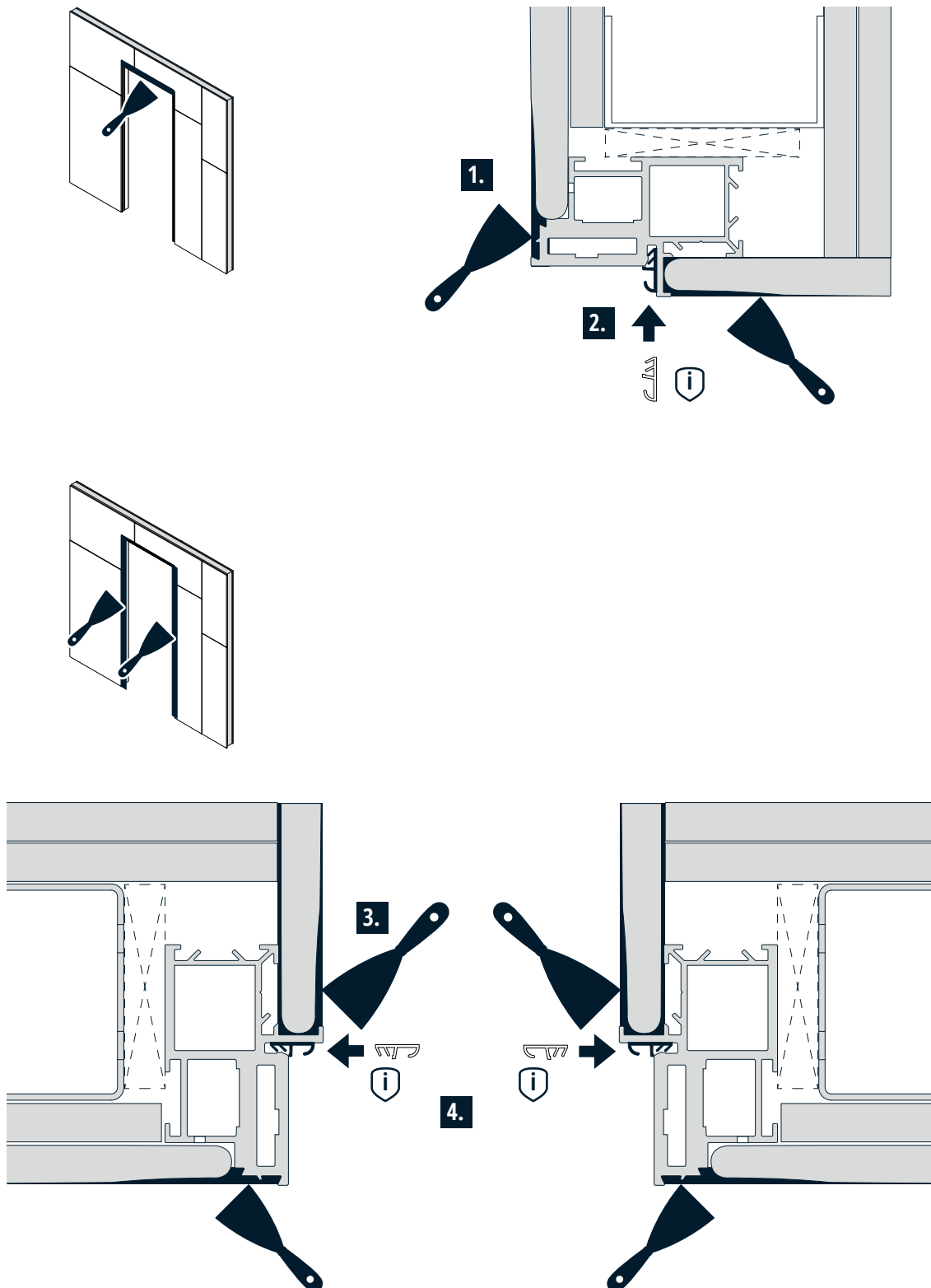



BAUTEILE

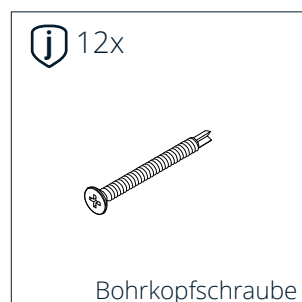
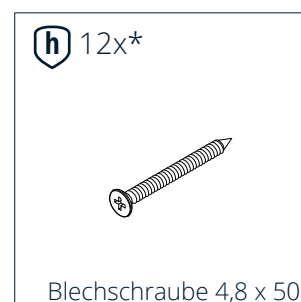
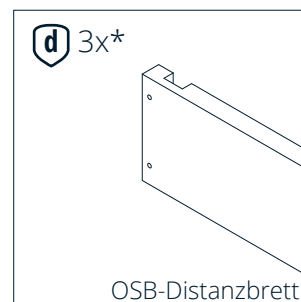
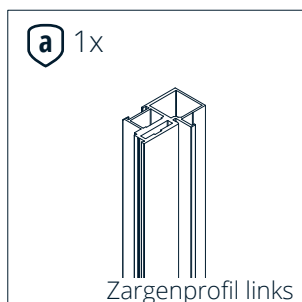

* Die Anzahl wird auf die jeweilige Einbauhöhe des Sets abgestimmt und kann unterschiedlich ausfallen.

** Für eine doppelte Beplankung ausgelegt



ALLE TEILE IM ÜBERBLICK

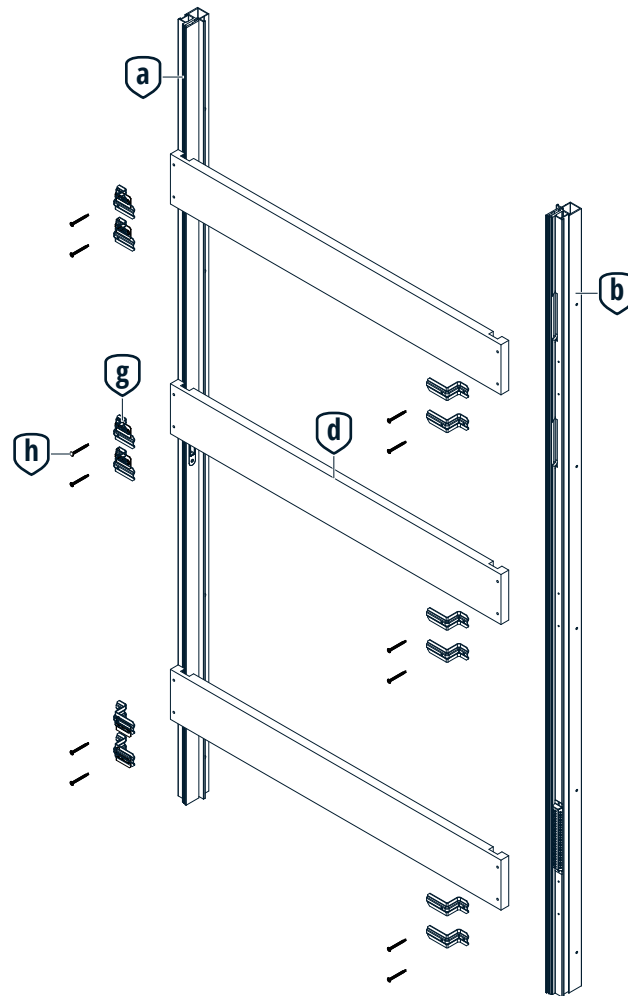



1.

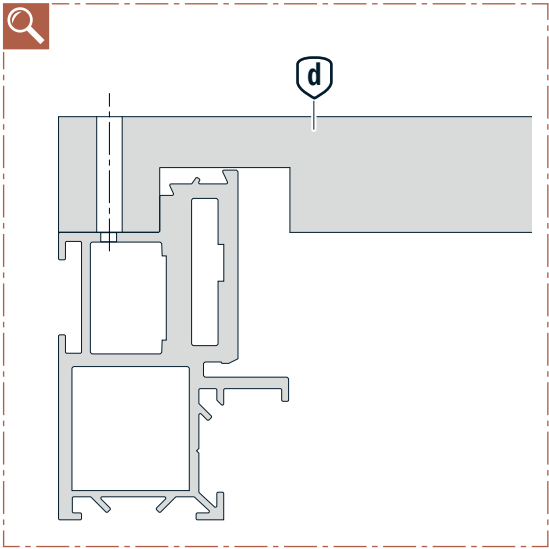
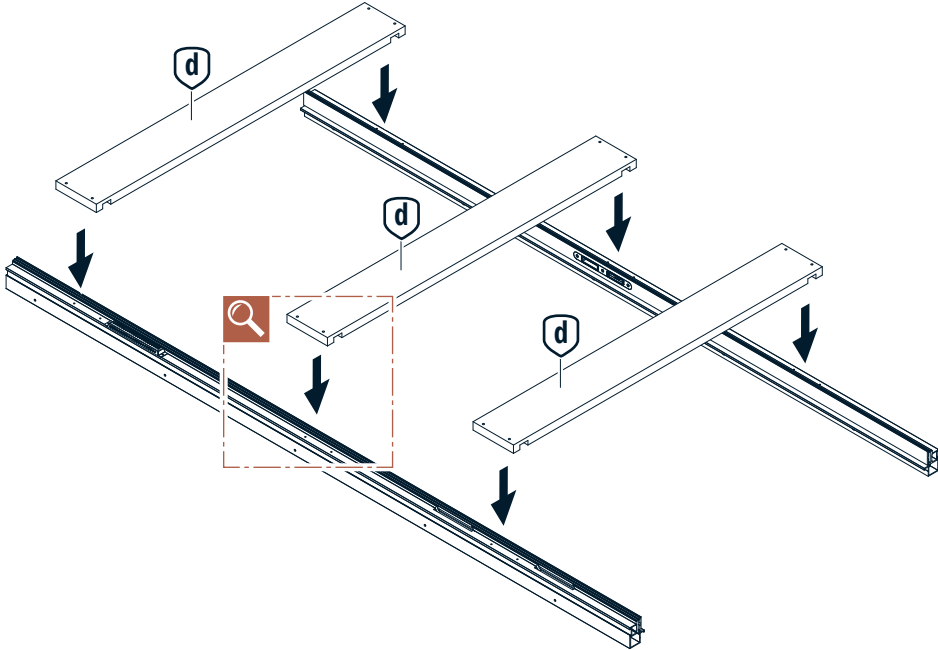



2.

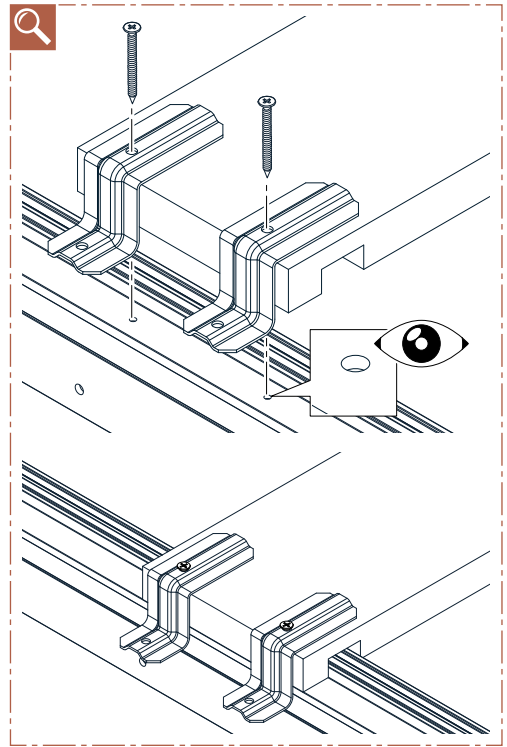
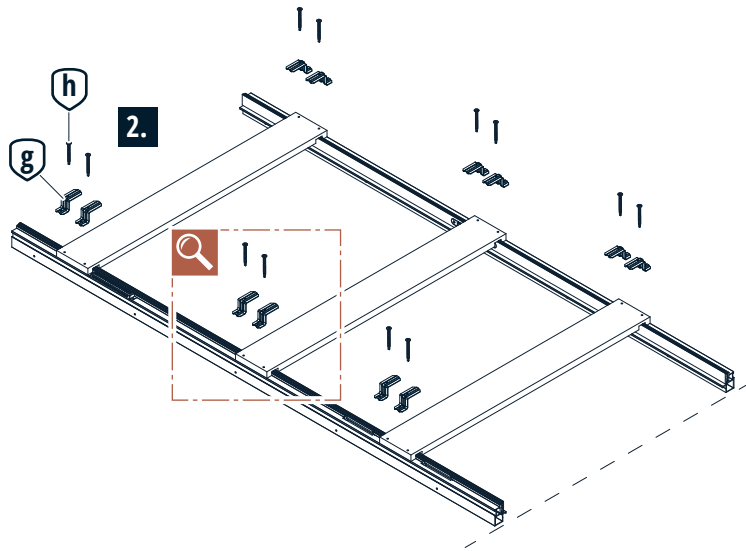
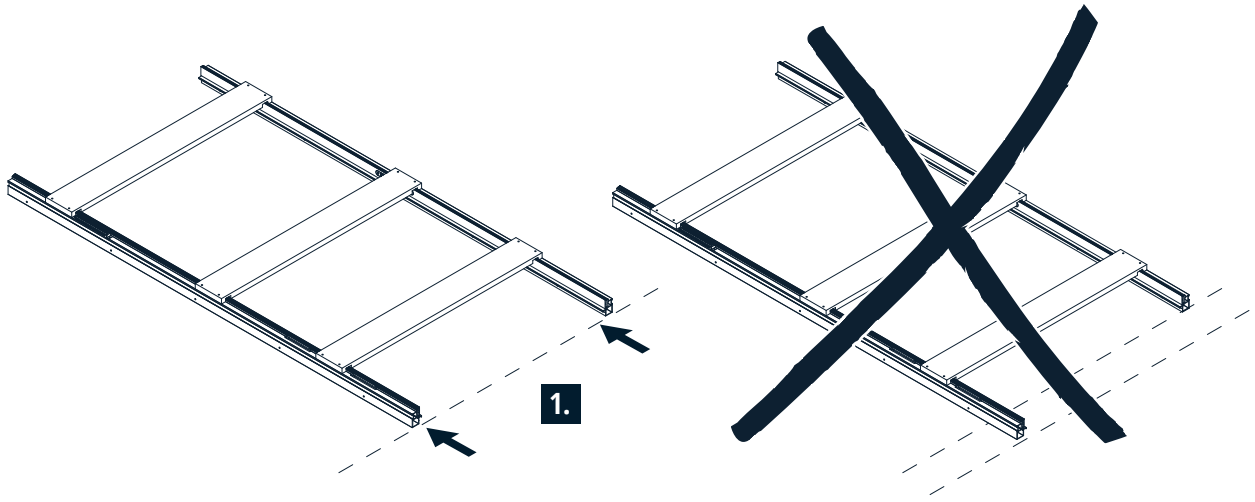



3.

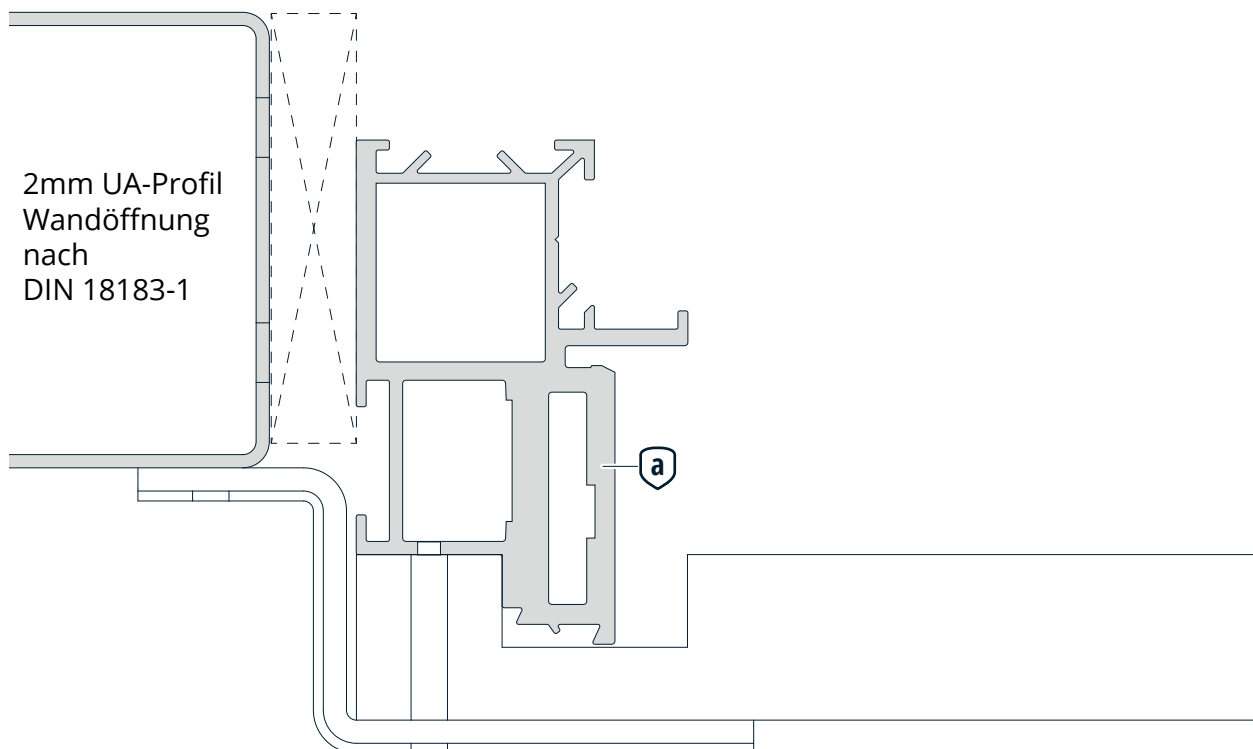
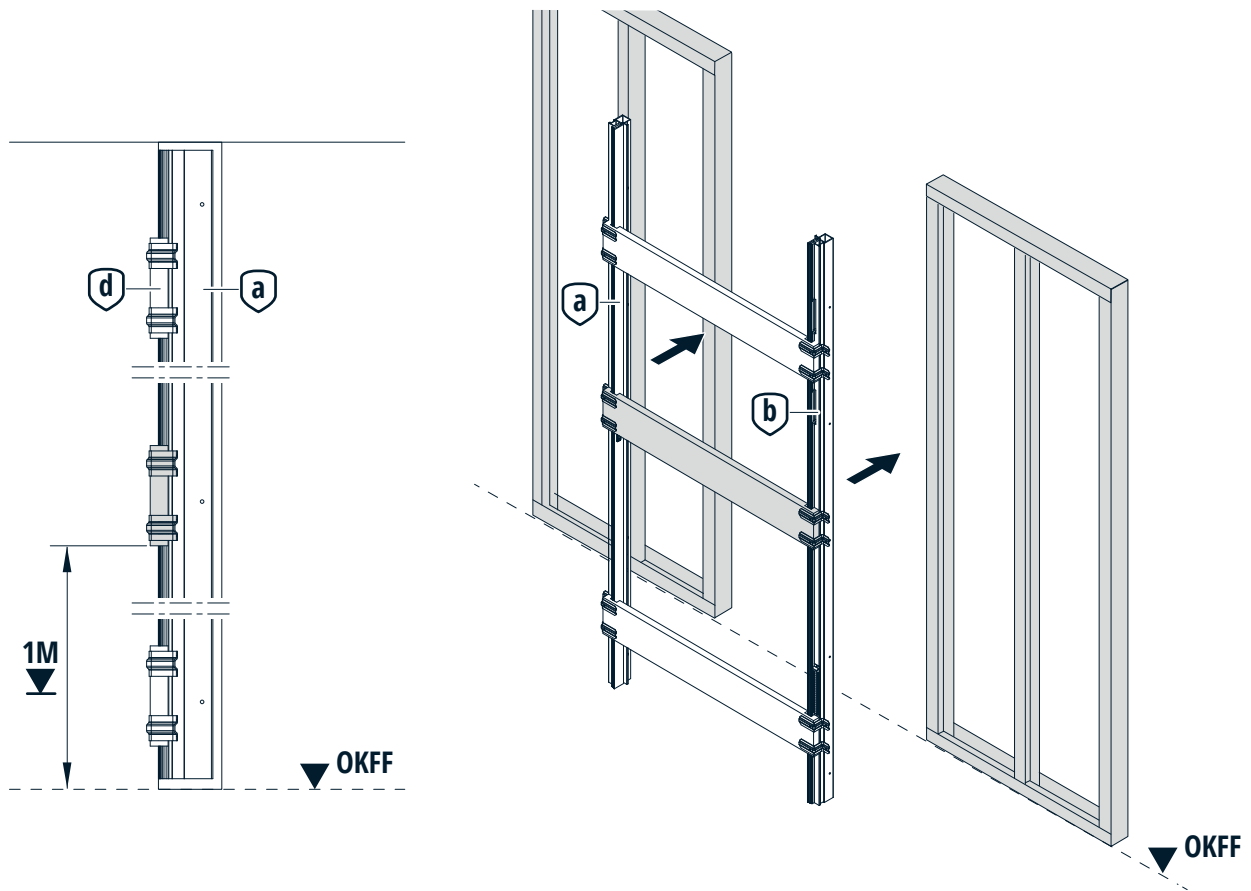



4.

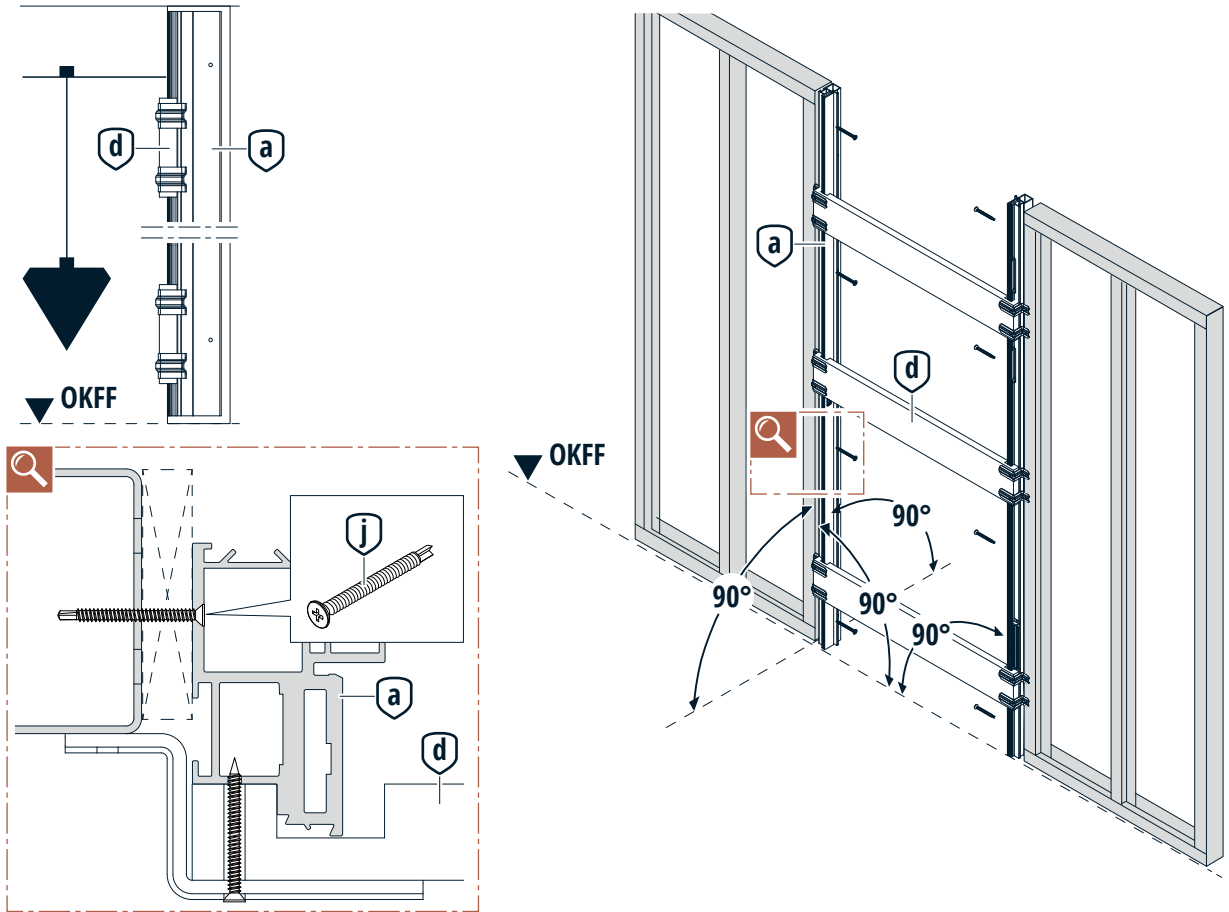

5.

HINWEIS:
Erst nach kompletter Verankerung
entfernen!

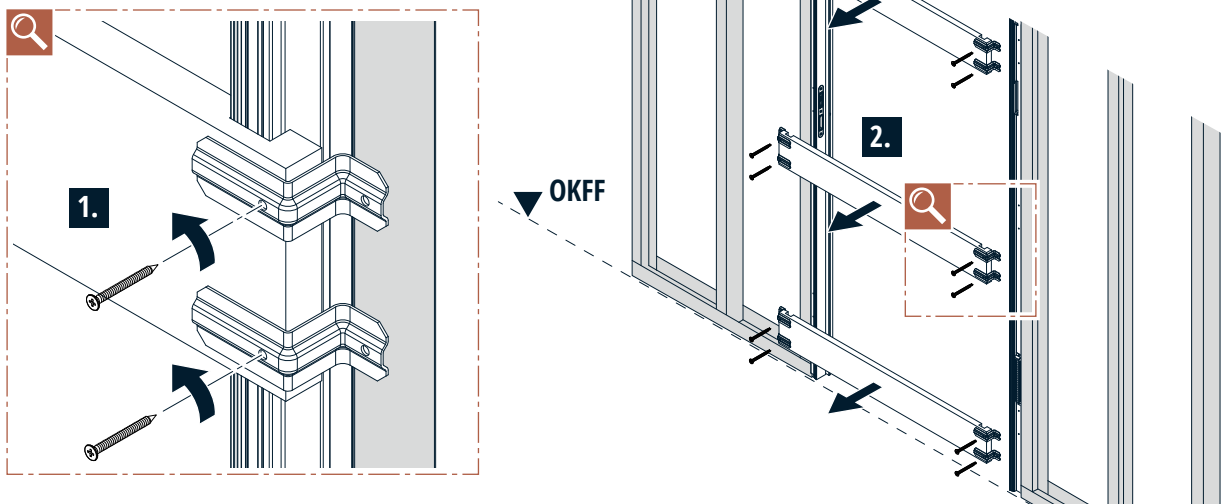



6.

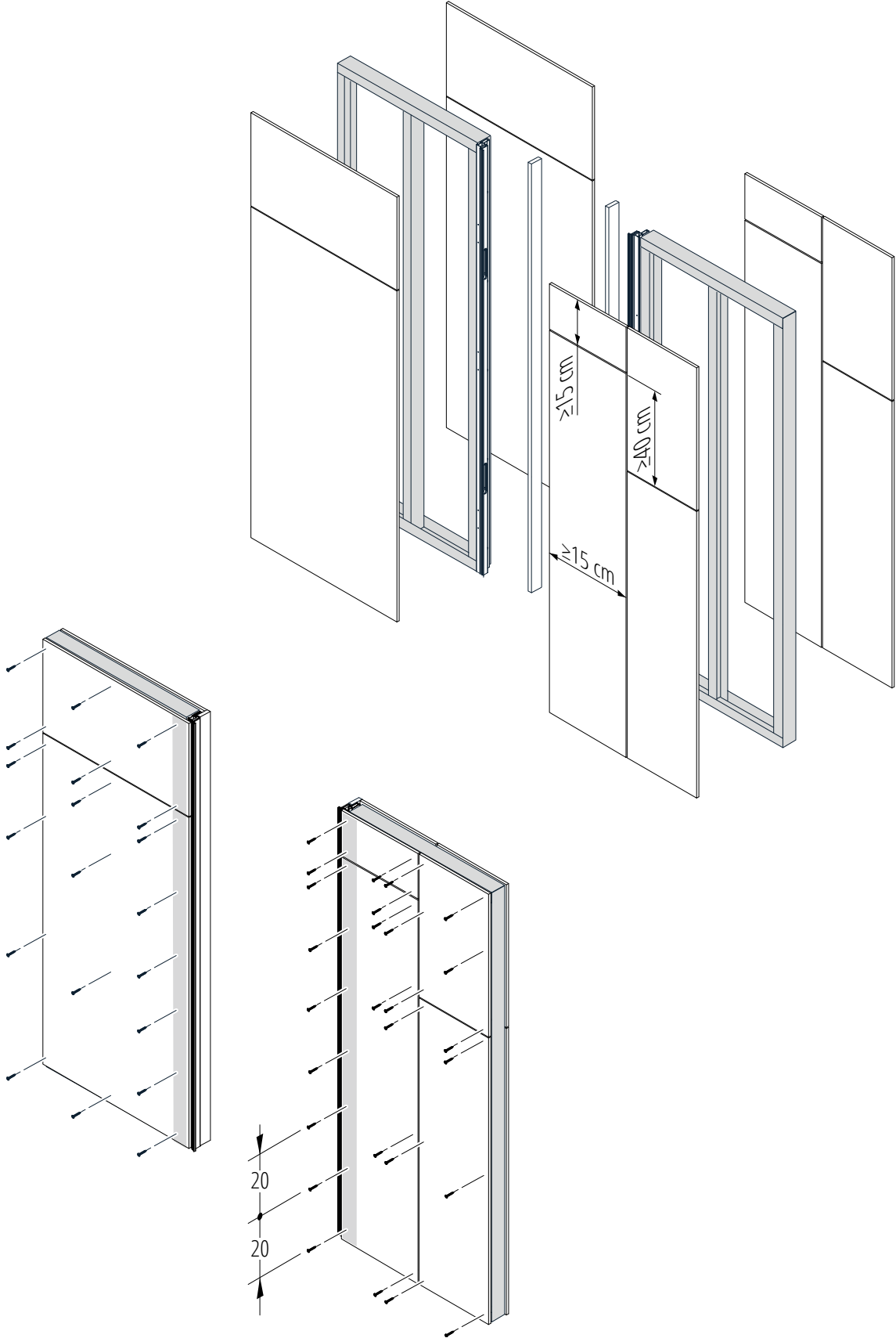



7.

A

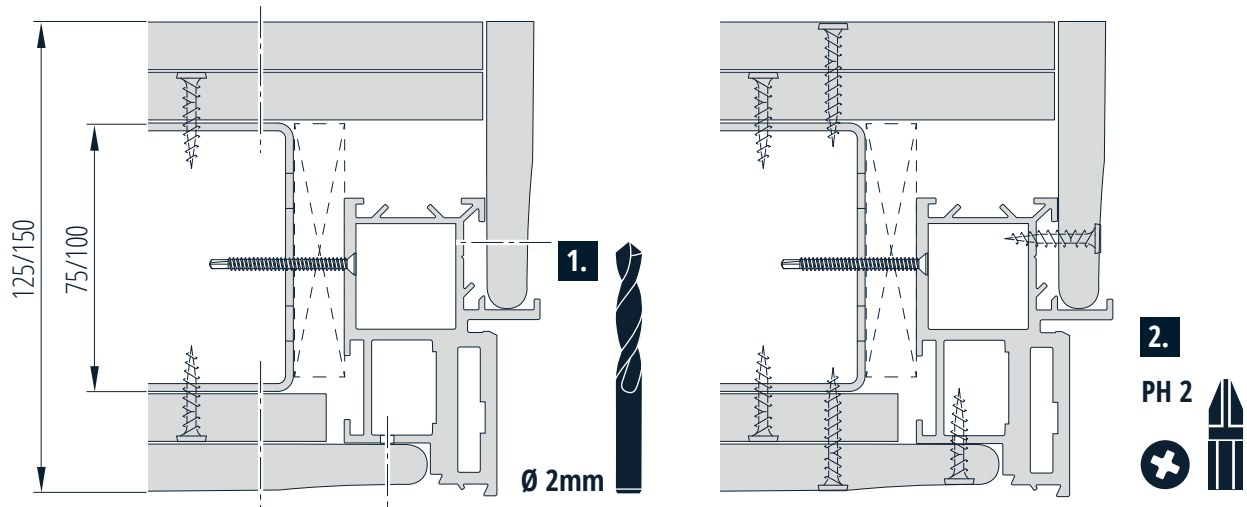

B

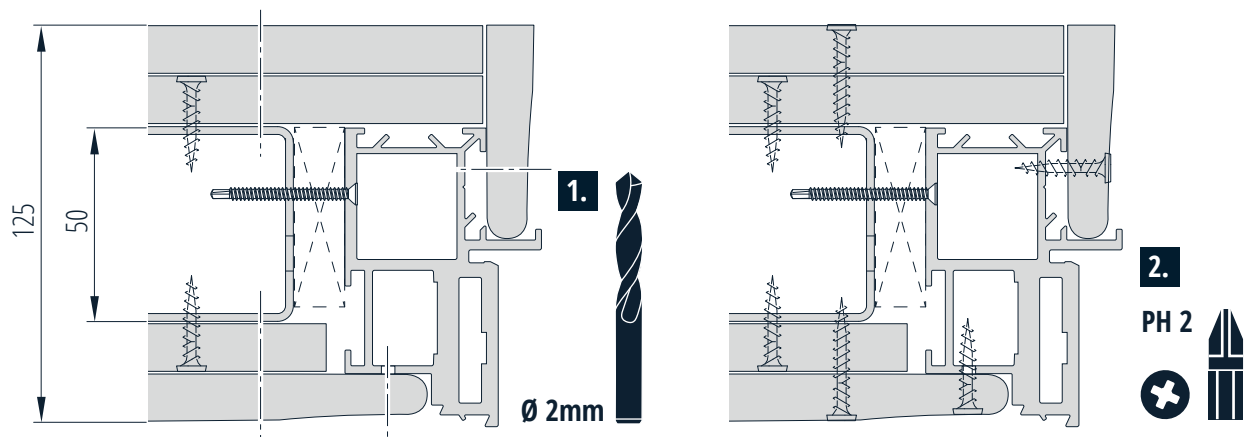



8.

HINWEIS:

Die Verwendung von kunststoffvergüteter Spachtelmasse mit Glasfaser- Fugendeckstreifen wird empfohlen.

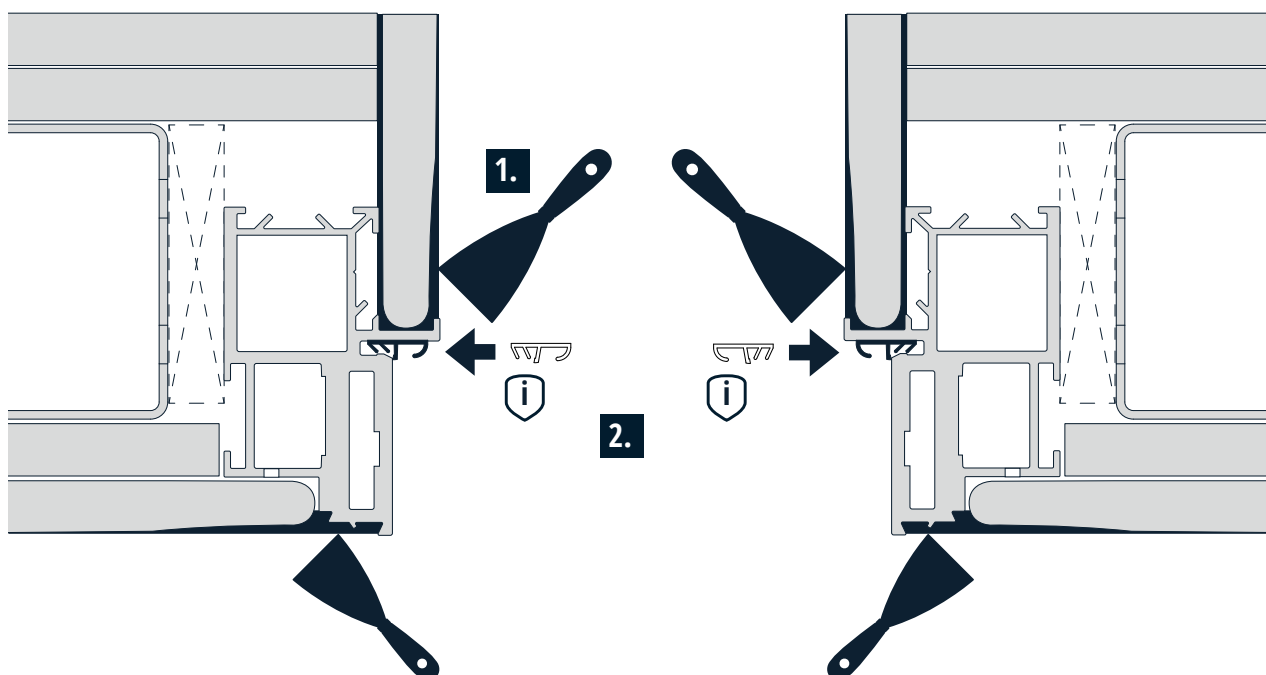
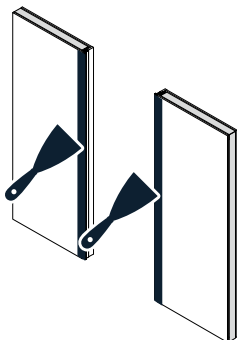



Verarbeitungshinweise

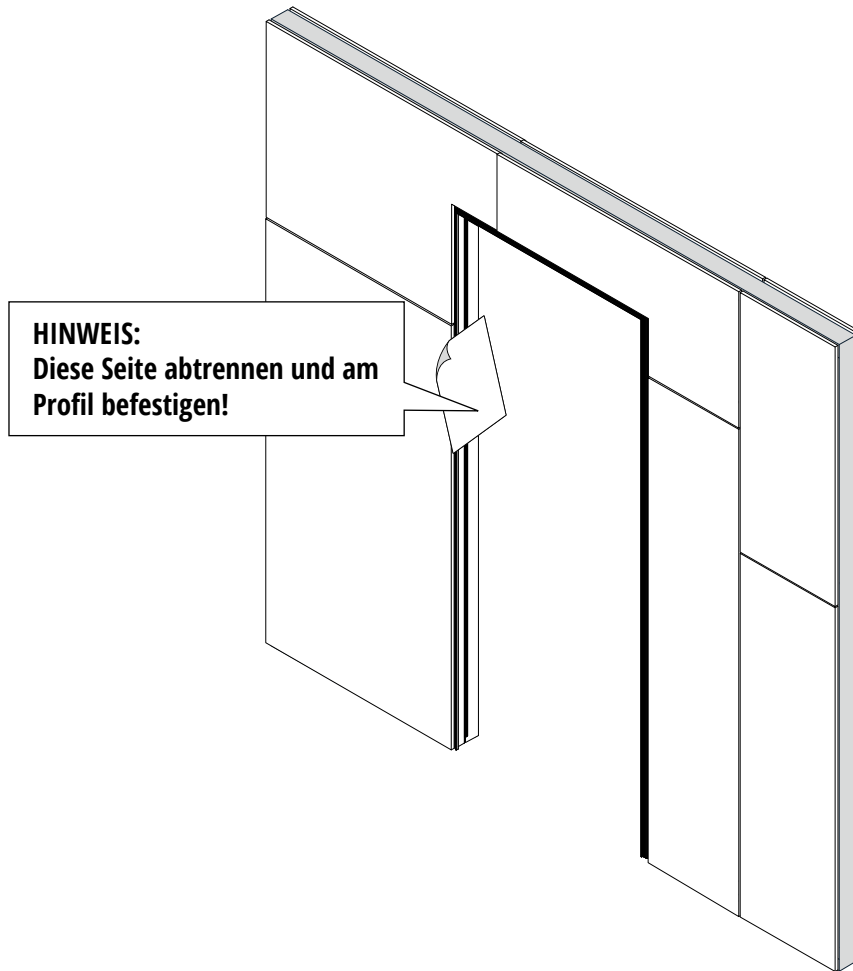

Bodenübergangsfuge



Endbehandlung der grundierten Oberfläche mit Alkydharz-, Nitro-, Polyurethan-, Acrylfarbe



WINGBURG

 **+49.5257.94792-0**
 **info@wingburg.de**
 **www.wingburg.de**